

SERPENT VIPER

GP 1/8 scale onroad

INSTRUCTION
MANUAL



SPT
SERPENT
INNOVATIONS

**WORLD
CHAMPIONS
10X**

INTRODUCTION

The Serpent Viper 988 is designed to be a world champion, while still being easy to use, assemble, and set up. The Serpent Viper 988 offers state of the art specifications and leads the way in chassis design, using all the knowledge we have from 1/8 scale racing into this design too. Continuously pushing the performance envelope, Serpent's engineers have added new and innovative features that help take your Serpent Viper 988 into the winner's circle.

Designed by Michael Salven

Team Serpent
Multiple World Champions

INSTRUCTIONS

Serpent's long tradition of excellence extends to the instruction manuals, and this instruction manual is no exception. The easy-to-follow layout is richly illustrated with 3D-rendered full-color images to make your building experience quick and easy. Following the instructions will result in a well-built, high-performance race-car that will soon be able to unleash its full potential at the racetrack. The kit includes bags, with bag numbers, which refer to the same step in the manual. Open only the indicated bag(s) per step and finish that part of the assembly. Remaining parts will be needed later on in the assembly process.

PLASTIC PARTS

The Serpent moulded parts are very durable and hard. When assembling longer screws in new composite parts, make sure to use new hex bits in your (power) tools. Pre-threading also helps to avoid screw damage.

SETUP

In certain assembly steps you need to make basic adjustments, which will give you a good initial setup for your Serpent Viper 988. Fine-tuning the initial setup is an essential part of building a high-performance racecar like your Serpent Viper 988.

EXPLODED VIEWS AND PARTS LIST

The exploded views and parts lists for the Serpent Viper 988 are presented in the Reference Guide section in the back of this manual. The exploded views show all the parts of a particular assembly step along with the Serpent part number and hotlink to the Serpent website. Part numbers in orange indicates that this part is an optional. Optionals part names and numbers are showed below.

CUSTOMER SERVICE

Serpent has made a strong effort to make this manual as complete and clear as possible. Additional info may be published in our website: www.serpent.com or you may ask your dealer or the Serpent distributor for advice, or email Serpent direct: info@serpent.com. The Serpent Facebook, Twitter and Youtube pages give additional means of support and communications.

SAFETY

Read and take note of the 'Read this First section' before proceeding to assemble the car-kit. This car-kit is intended for persons aged 16 or older.

READ THIS FIRST!

- This is a highly technical hobby product, intended to be used in a safe racing environment. This car is capable of speeds in excess of 80 km/h or 50mph. Please follow these guidelines when building and operating this model.
- Parental guidance is required when the builder/user of this car is under 16.
- Follow the building instructions. If in doubt, contact your dealer or importer.
- Be sure to use the proper tools when assembling the car. Always exercise caution when using electric tools, knives and other sharp objects.
- Be careful when using liquids like lubrication oil, fuel or glue. Do not swallow.
- Follow the manufacturer's instruction in case you experience irritation after using the product.
- Be careful when operating the car. Stay away from any rotating parts such as wheels, gears and transmission. Stay away from motor, engine and exhaust pipe system or speedo during and immediately after use, as these parts may be very hot. We advise to use protective hand gloves.
- Only operate this car in a safe environment, like a special racing track or a closed parking lot. Avoid using this car on public roads, crowded places or near infants.
- Before operating this car, always check the mechanical status of the car. Also check that the transmitter and receiver frequencies correspond and are not used by any other racer at the same time. Check that the batteries of the transmitter and receiver- are fully charged.
- After use, always check all the mechanics of the car. We advise to clean the car immediately after use, and inspect the parts for wear or fractures. Replace when necessary. Do not use water, methanol, thinner or other solvents to clean the car.
- Empty the fuel tank (depending on model) if needed and disconnect the receiver battery.
- Store the car in a dry and heated place to avoid corrosion of metal parts.
- Avoid using this car in wet conditions as the water will cause corrosion on the metal parts and bearings and these parts will cease to function properly. If driven in the wet, ensure that all the electric equipment is waterproofed and after use, that all moving parts are dried immediately.

CONTENTS

•		
•	REAR ASSEMBLY	4
•	GEARBOX ASSEMBLY	16
•	FRONT I ASSEMBLY	18
•	RADIO ASSEMBLY	26
•	SHOCKS ASSEMBLY	36
•	CLUTCH ASSEMBLY	41
•	FINAL ASSEMBLY	43
•	EXPLODED VIEWS	48

lines DESCRIPTION

Each step contains a variety of numbers, lines, and symbols. The numbers represent the order in which the parts should be assembled. The lines are described below.



Step number; the order in which you should assemble the indicated parts



Length after assembly



Assembly path of one item into another

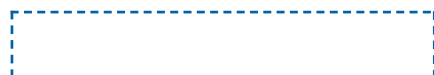

Group of items (within lines) should be assembled first



Direction the item should be moved



Glue one item to another



Connect one item to another



Gap between two items



Press/Insert one item into another

ICONS DESCRIPTION

Each step contains a variety of symbols described below.



Carefull, read and check very well.



Apply a small amount of cyano glue. Use wear protection for eyes and hands.



Detail view to explain assembly or order of parts better.



Default set-up: This symbol indicates the default setup.



Grease: apply a small amount of grease to the parts shown.



Silicone grease: apply a small amount of grease to the parts shown.



Thread lock: apply a small amount on the parts shown. Before to apply the threadlock, make sure to degrease the parts very well, as otherwise the threadlock will not work.



Silicone oil: use the indicated silicone oil for the shocks and differentials.



Oil: apply a small amount of oil to the parts shown.



Left and right parts should be assembled in the same way.



Parts or items not included in the kit.



Optional part, not standard in the kit.

STEP 1 bag 1

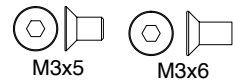
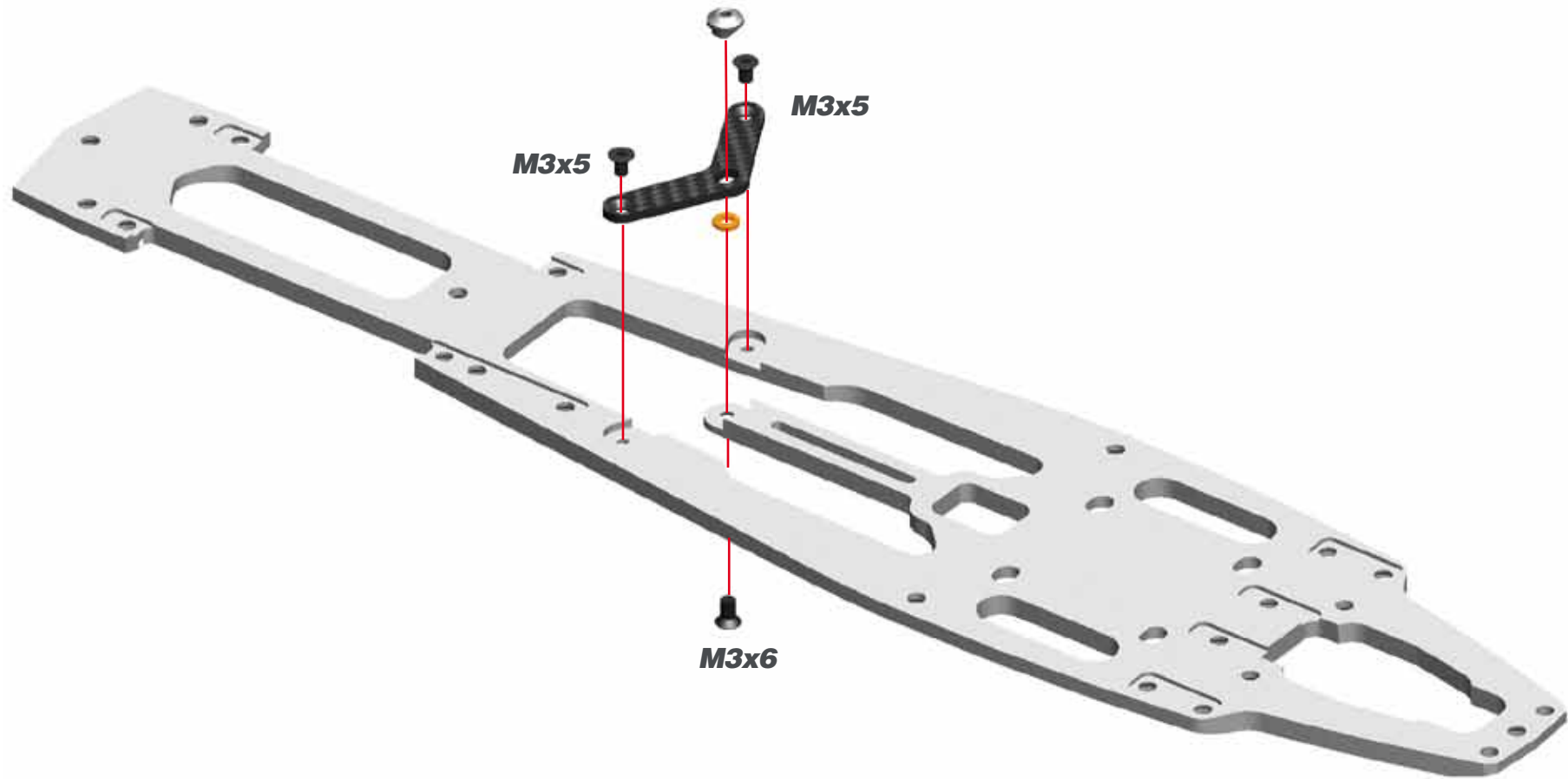

STEP 2

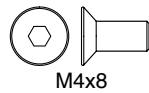
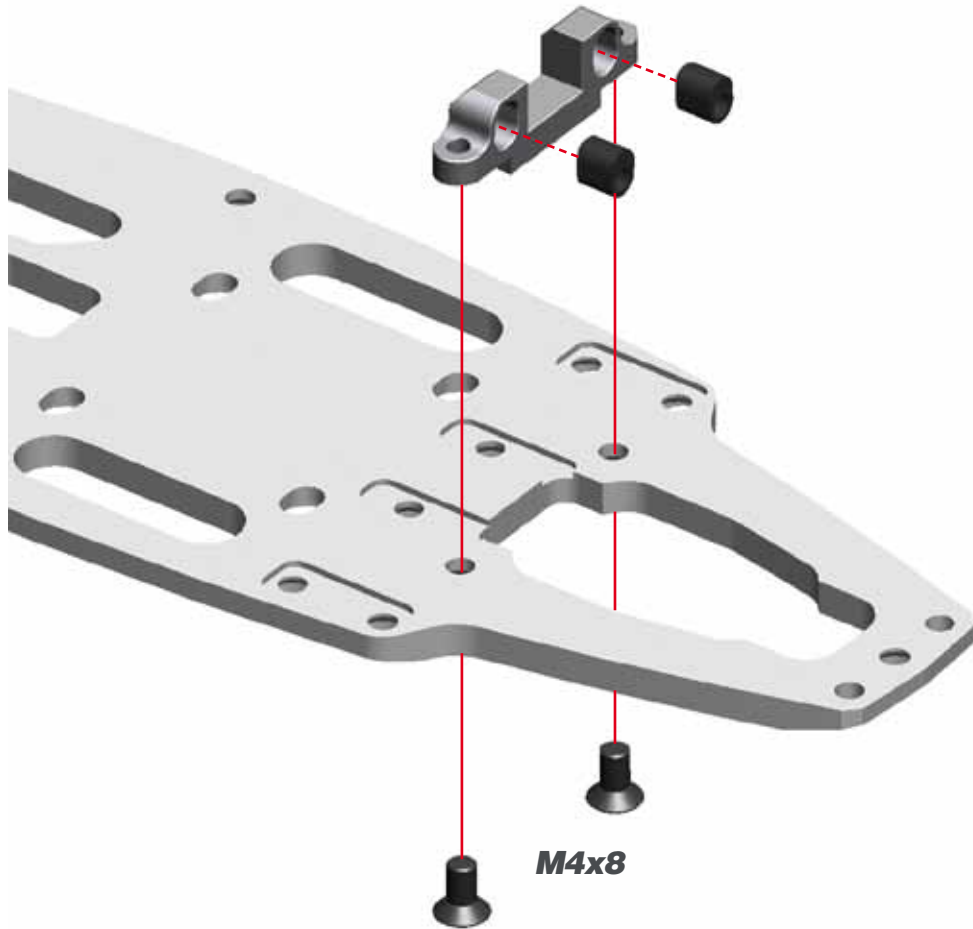

STEP 3

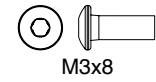
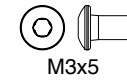
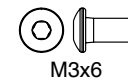
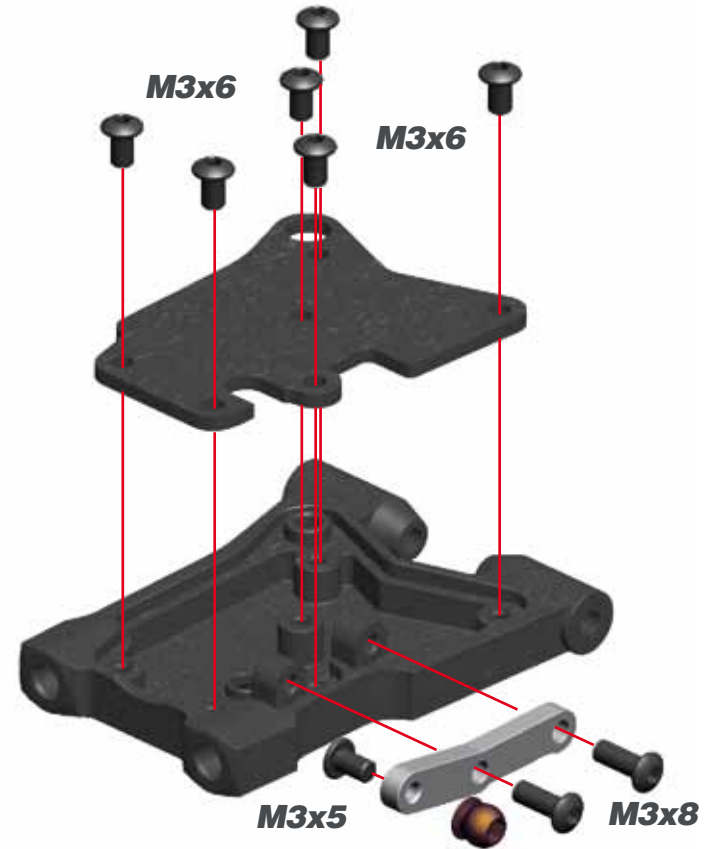

STEP 4

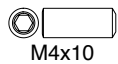



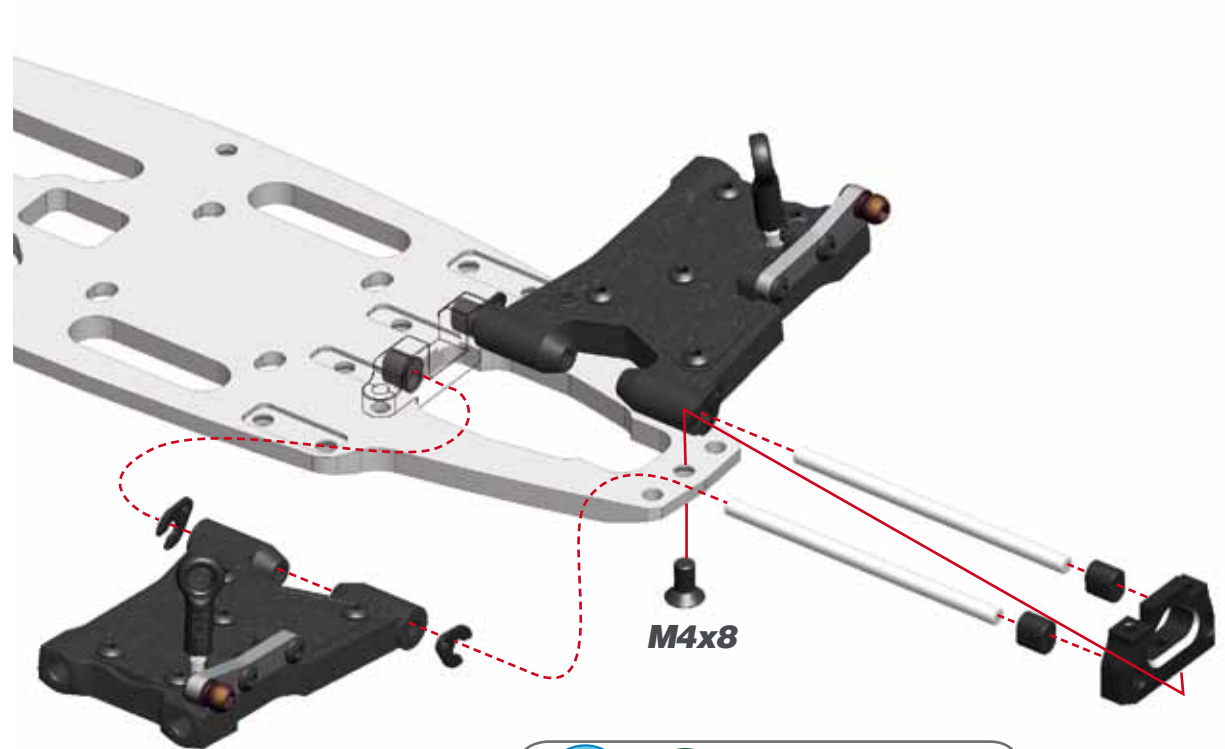

M4x10

STEP 5



M4x8

 **L=R** REAR ROLL CENTER
INSERTS CHART

REAR FRONT	REAR REAR
	
	



M4x8

STEP 6 **bag 2**

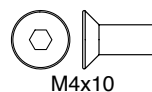
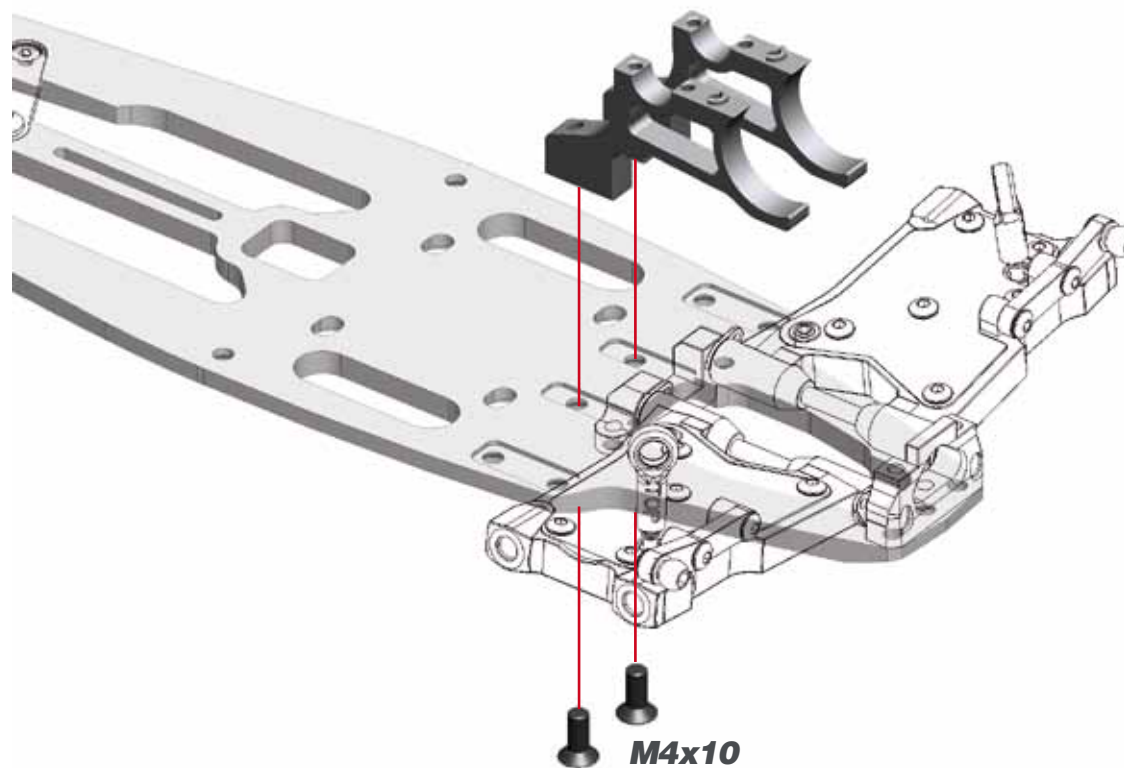

M4x10

STEP 7

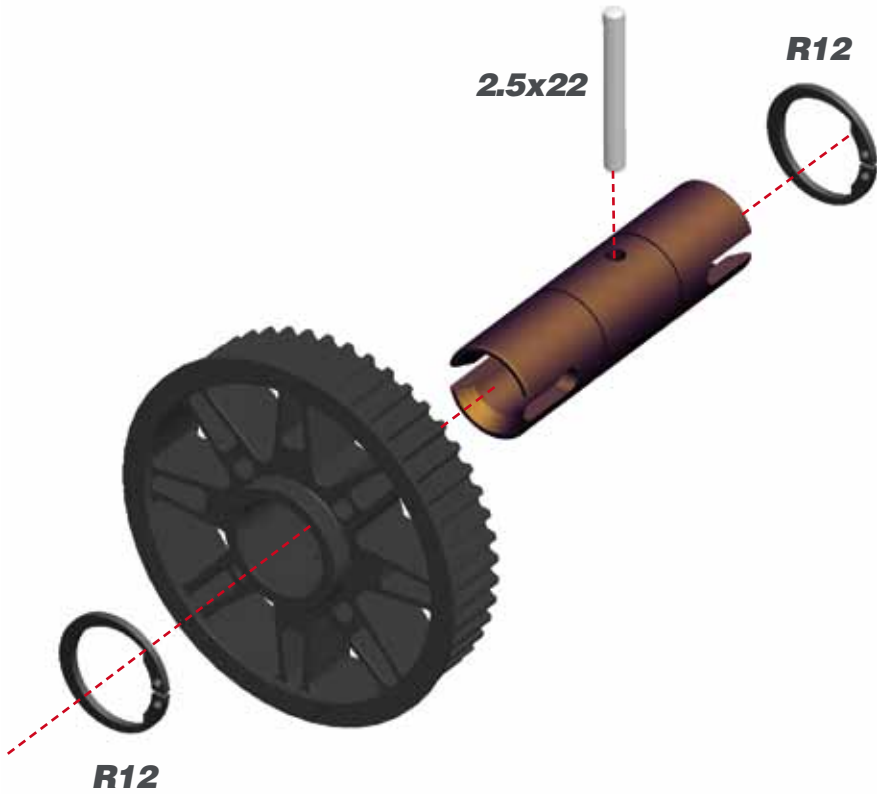

STEP 8



REAR SOLID AXLE EXCENTERS

Note that the rear solid axle excenters are not symmetric and are marked with L (left) and R (right).

LEFT

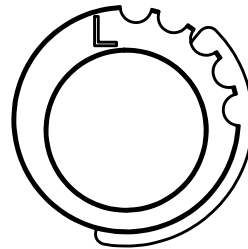

RIGHT

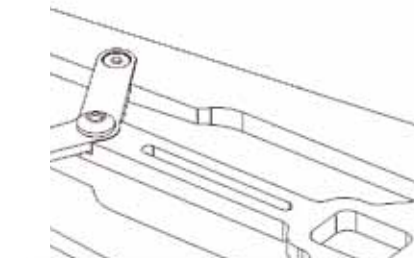
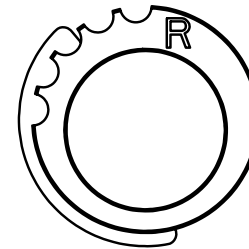

REAR BELT TENSION

Use the central slot as starting position



M3x10

3

M3x8

2

12x18x4

1

12x18x4

2

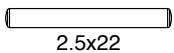
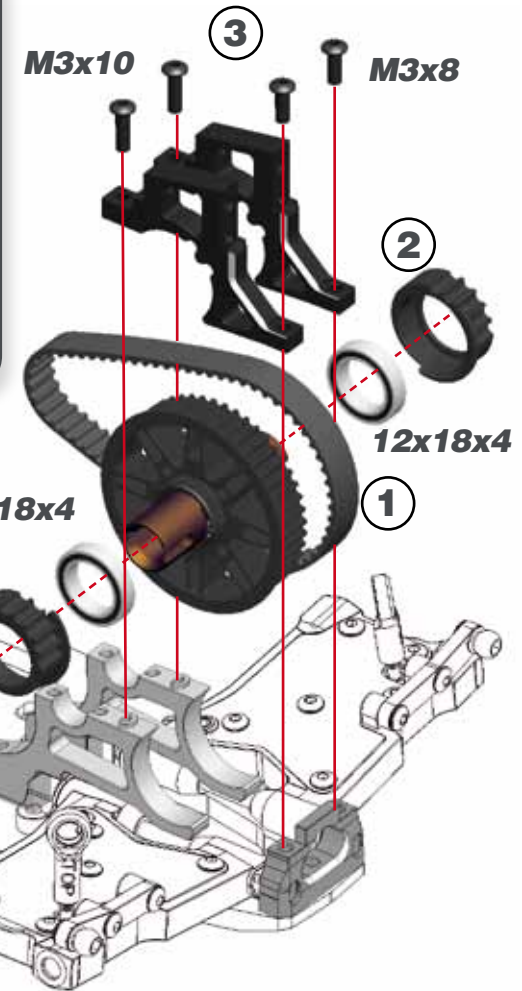

2.5x22

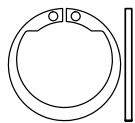

R12

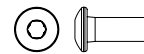

M3x8

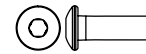

M3x10

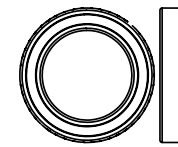

12x18x4

STEP 9

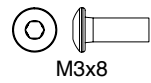
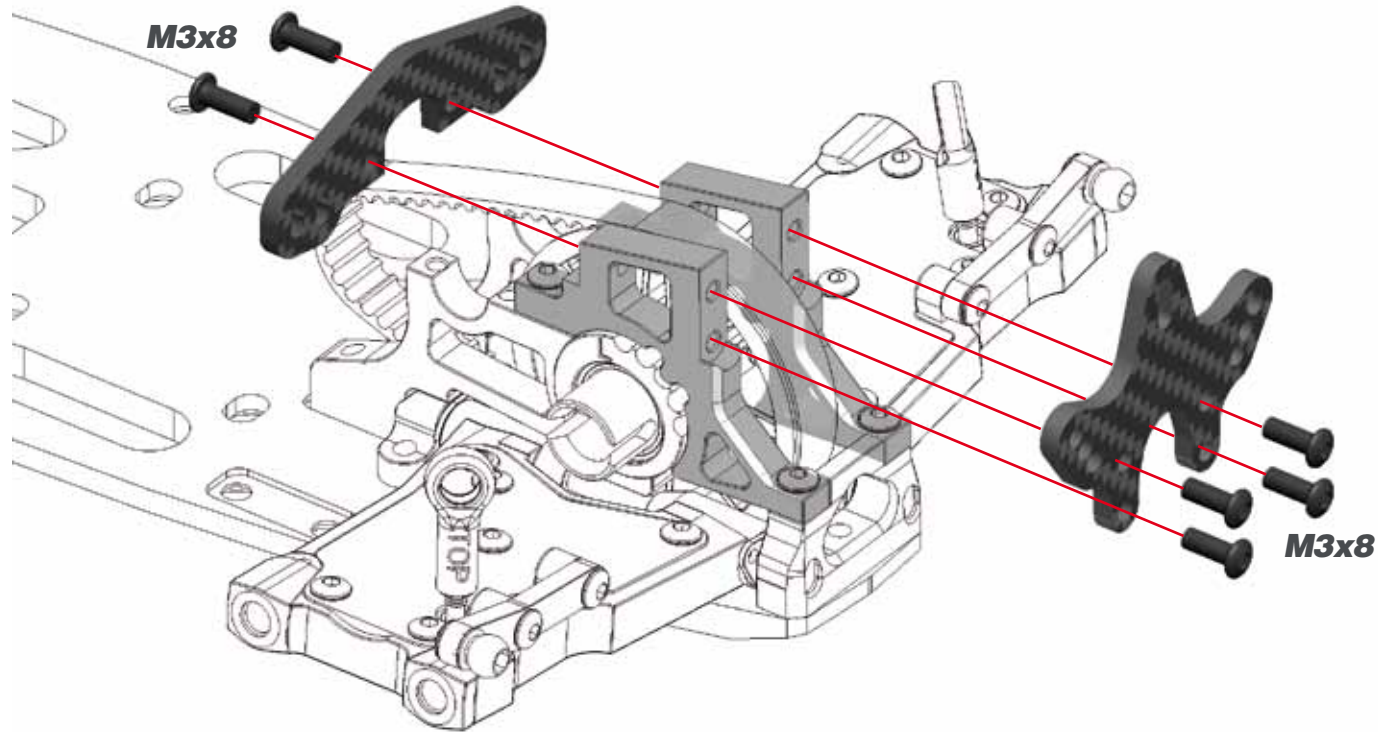

STEP 10.1



STEP 10.2

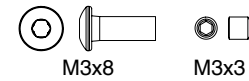
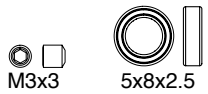
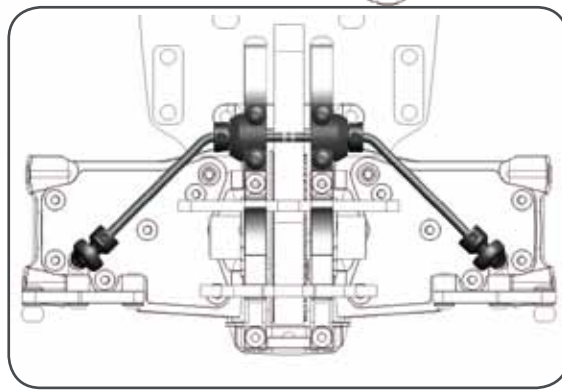
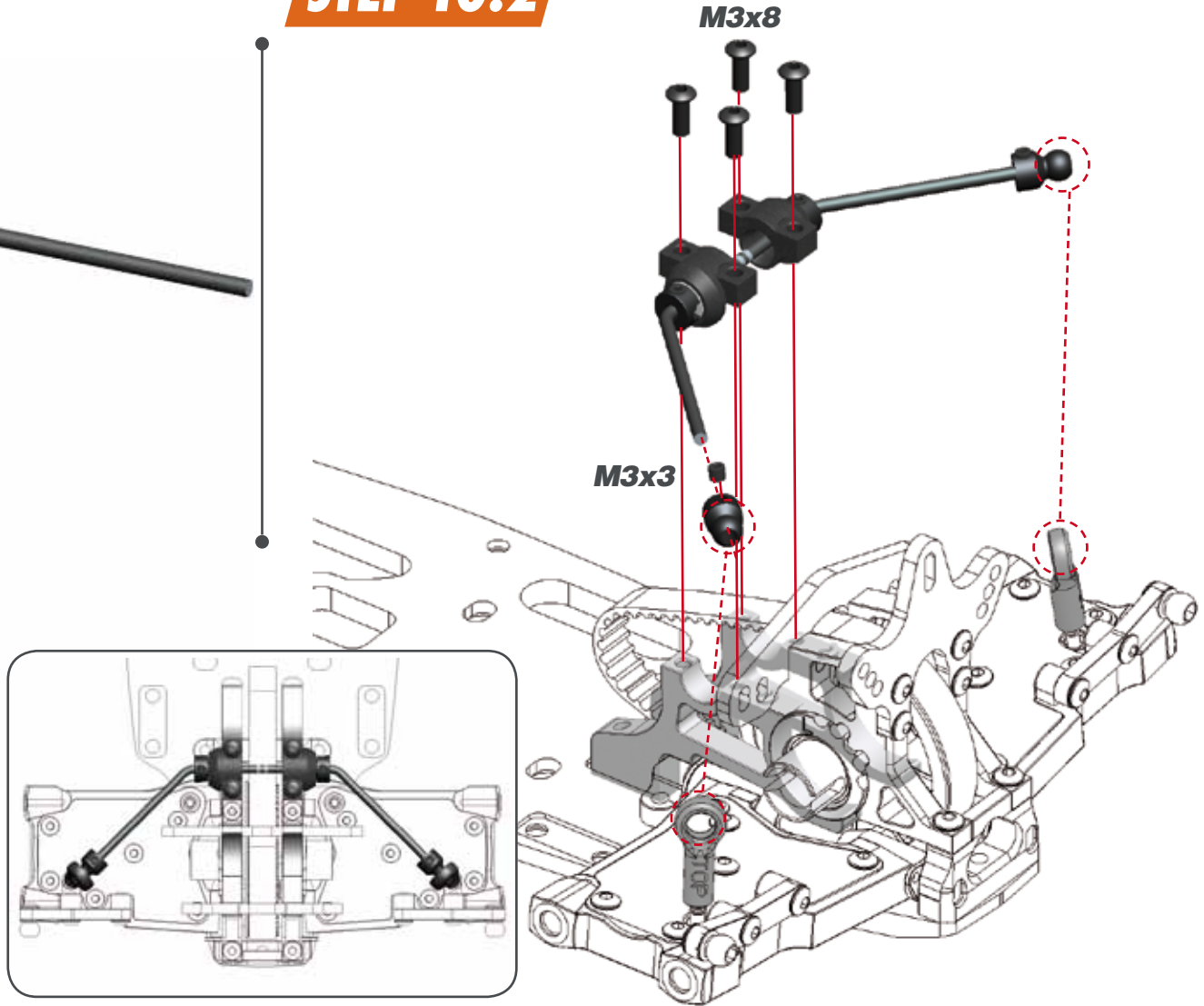



STEP 11.1 bag 3

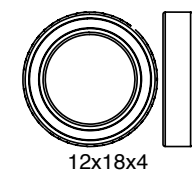
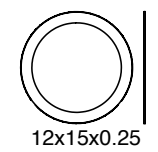
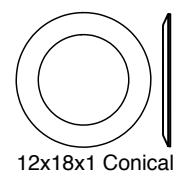
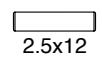
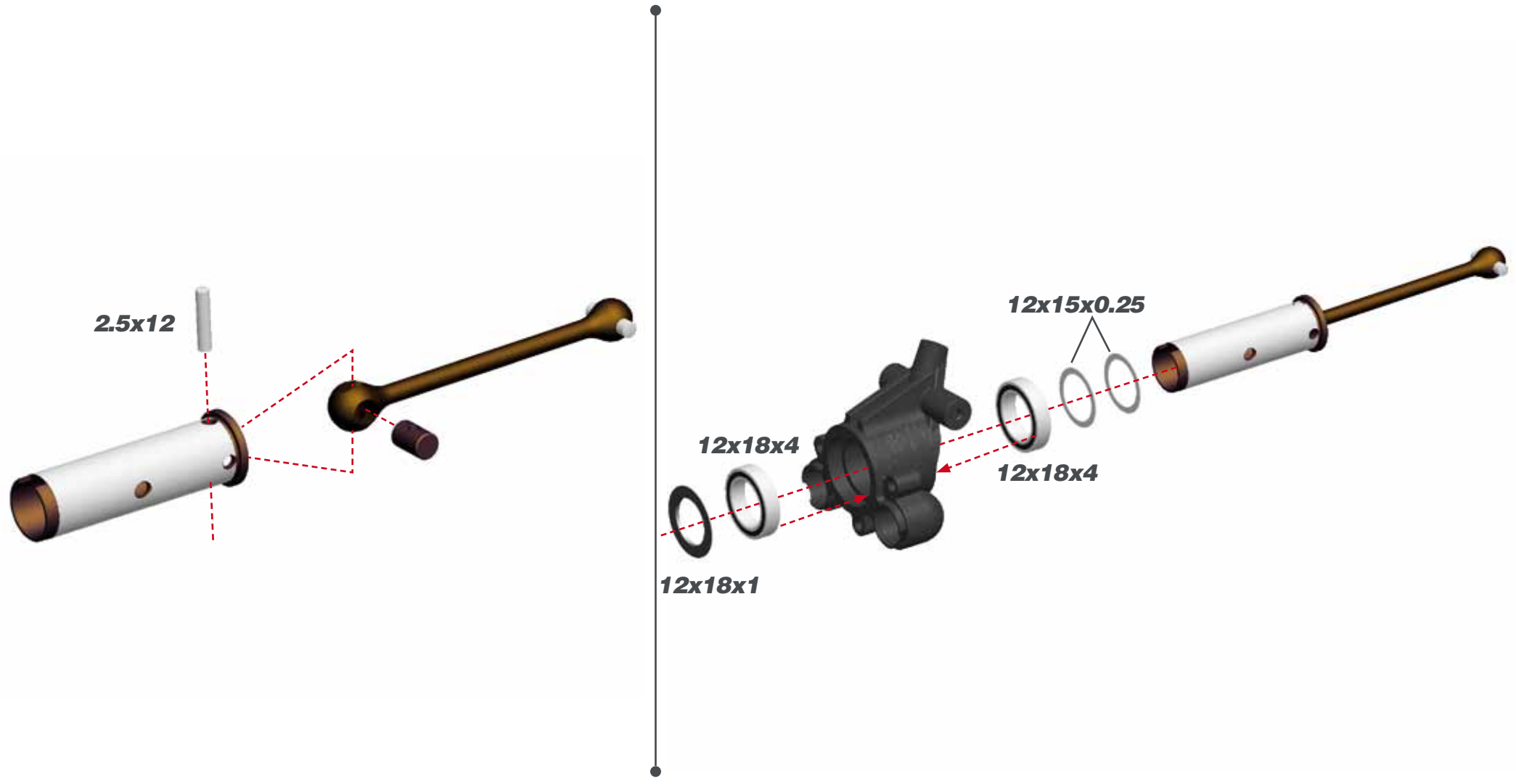

STEP 11.2

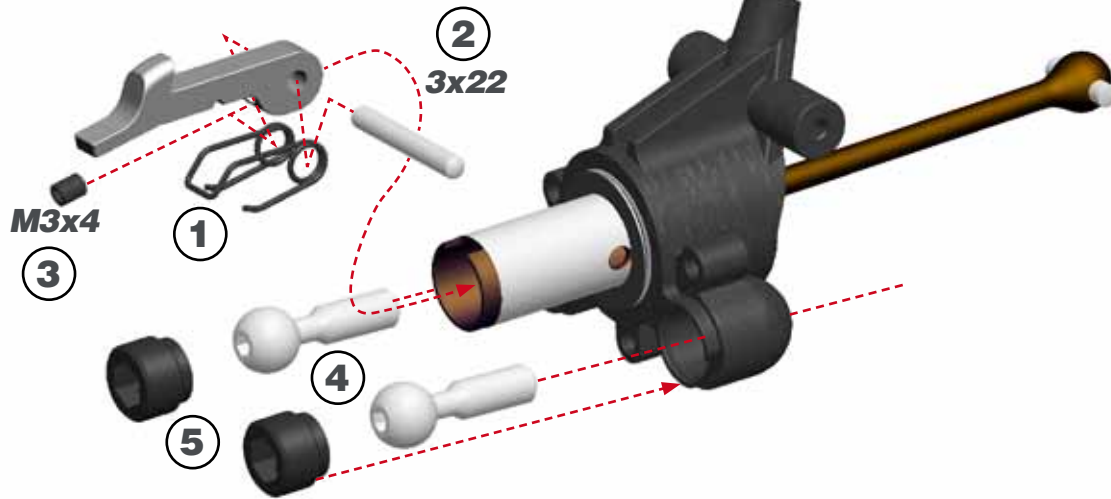

STEP 11.3



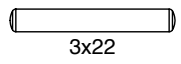

  1- Note orientation of the outside wheel axle shim.
2- Note position of the lever spring.

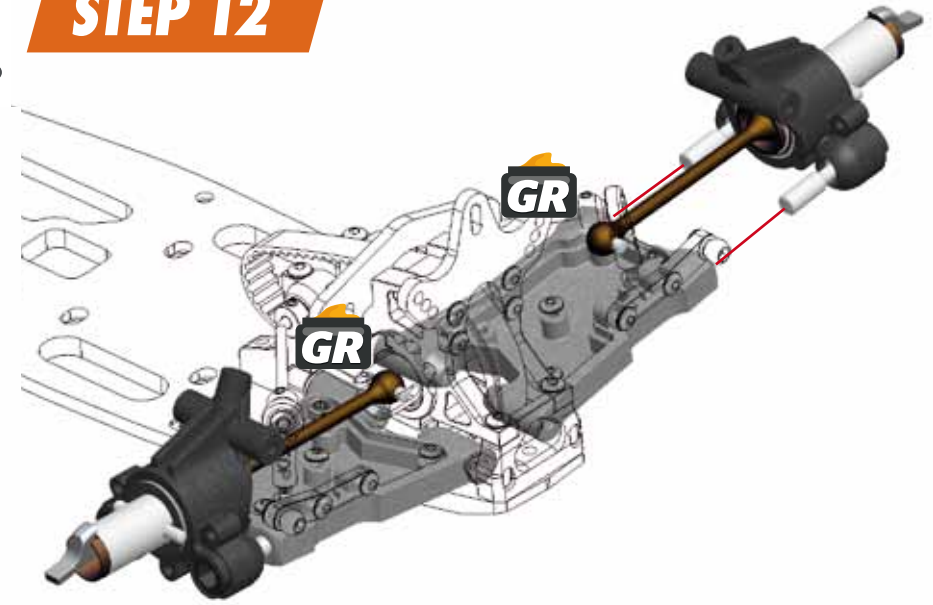

STEP 12



  REAR TRACK WIDTH

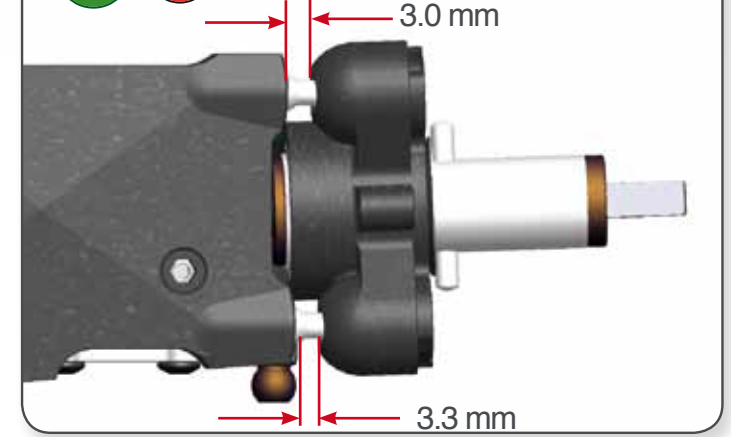



3.0 mm

3.3 mm

STEP 13.1





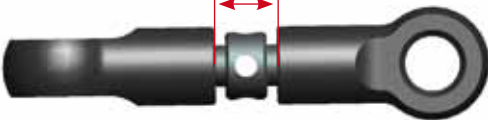

REAR CAMBERLINK LENGTH
 8.8 mm

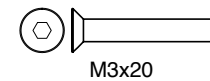
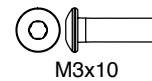
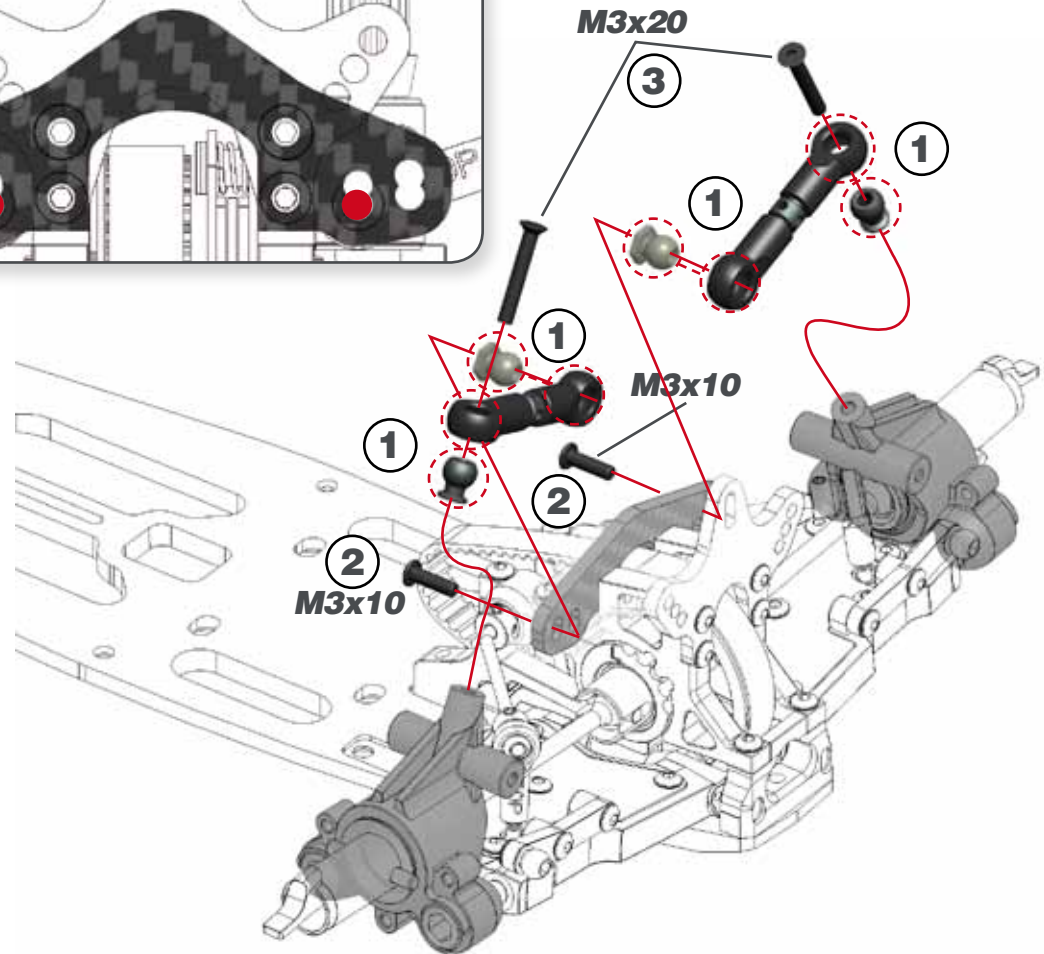
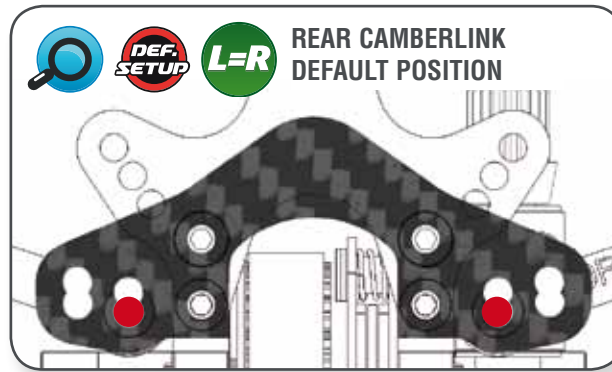

STEP 13.2

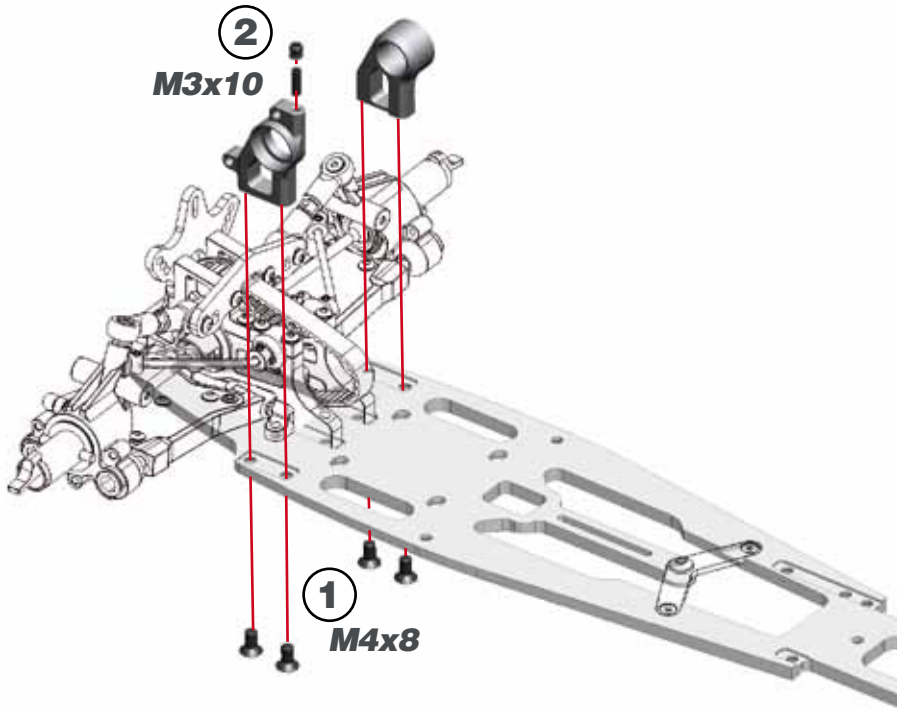

STEP 14 bag 4



STEP 15.1

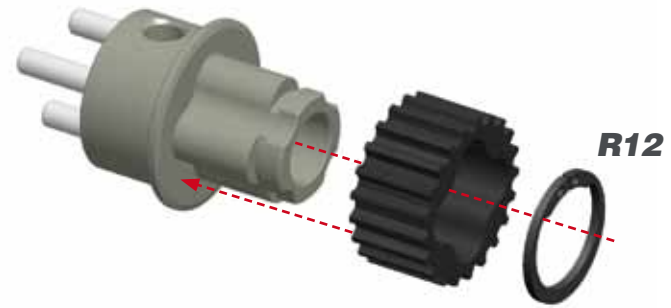

STEP 15.2

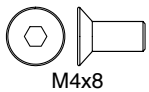
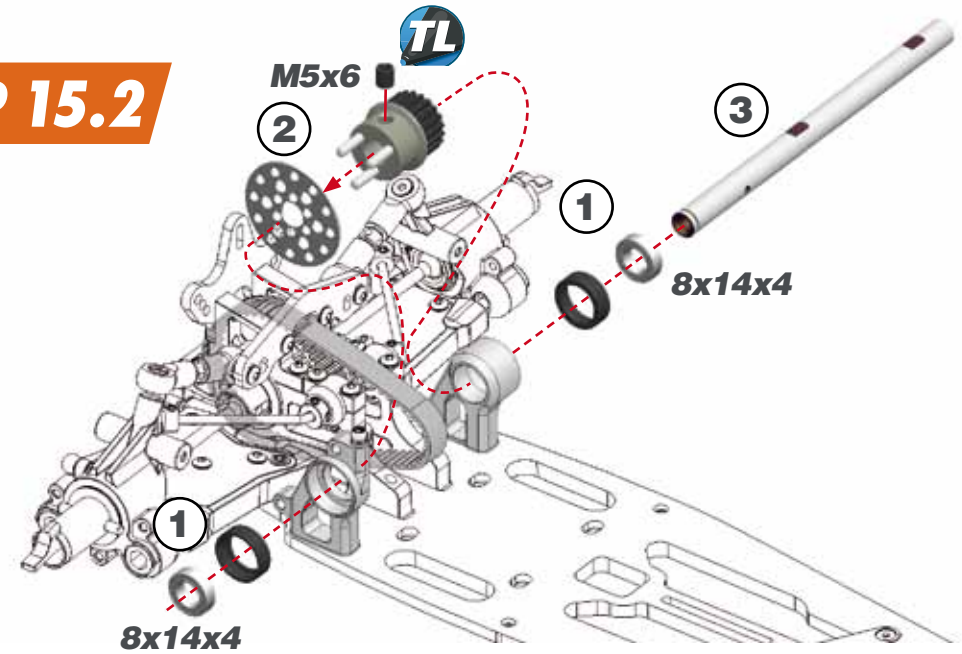

M4x8

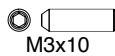

M3x10

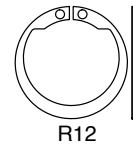

R12

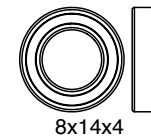

8x14x4

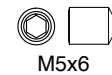

M5x6

STEP 16.1 bag 5

STEP 16.2

STEP 16.3

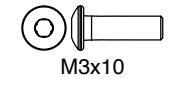
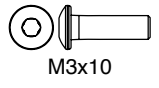
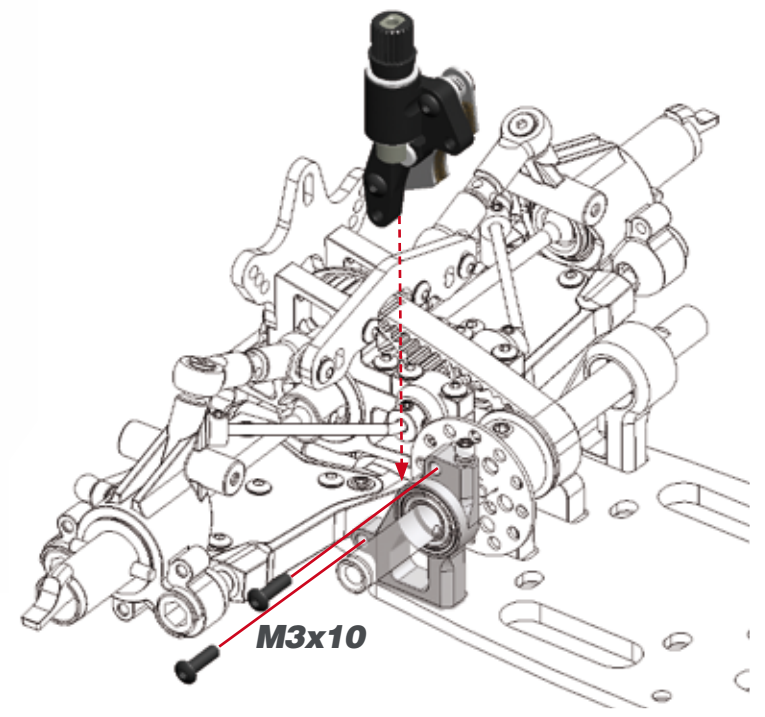
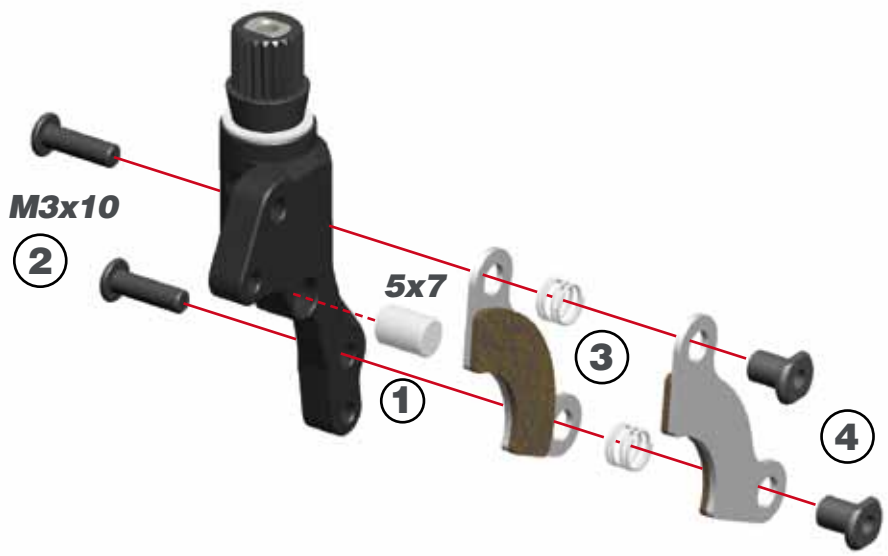

STEP 17.1

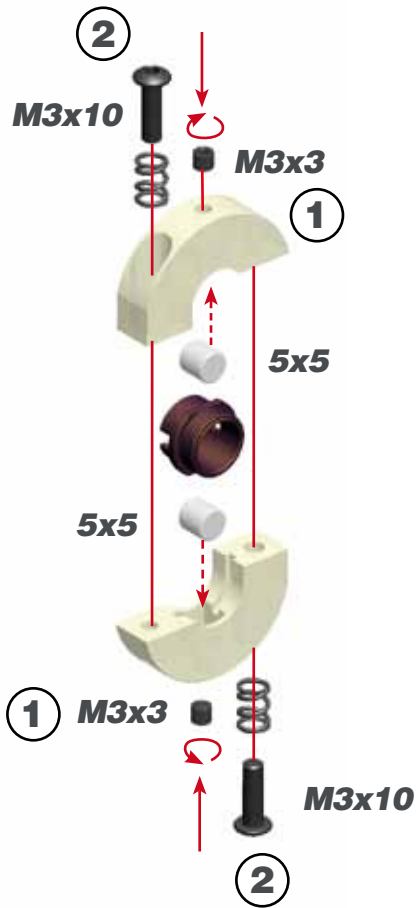

- 1- The M3x10 screw adjust the SHIFT POINT. As default adjustment screw it in all the way (do not over tighten the spring deforming it), then unscrew 3 turns.
- 2- Adjust the M3x3 screw to minimise the gap between the shoes to the bell. Check regularly.

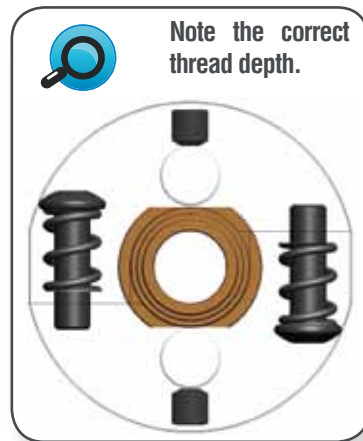

STEP 17.2

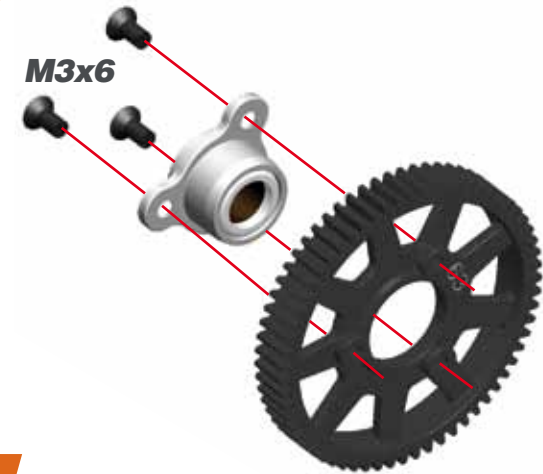

STEP 17.3

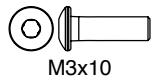
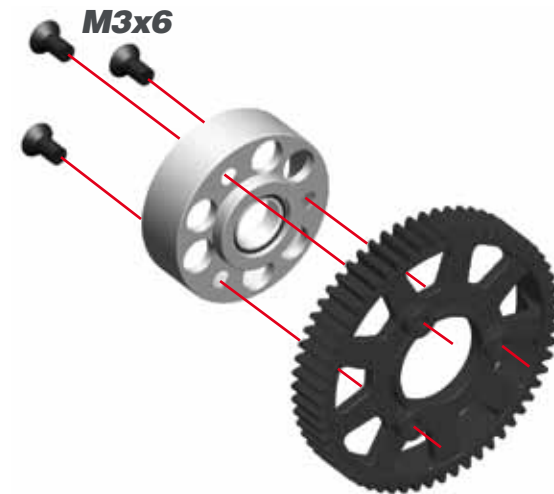

STEP 18.1

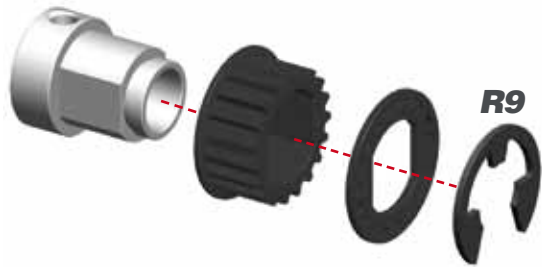

STEP 18.2

! Adjust the position of the side pulley to have a little play of the 2-speed shaft.

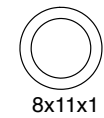
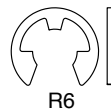
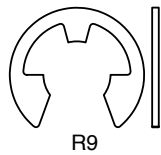
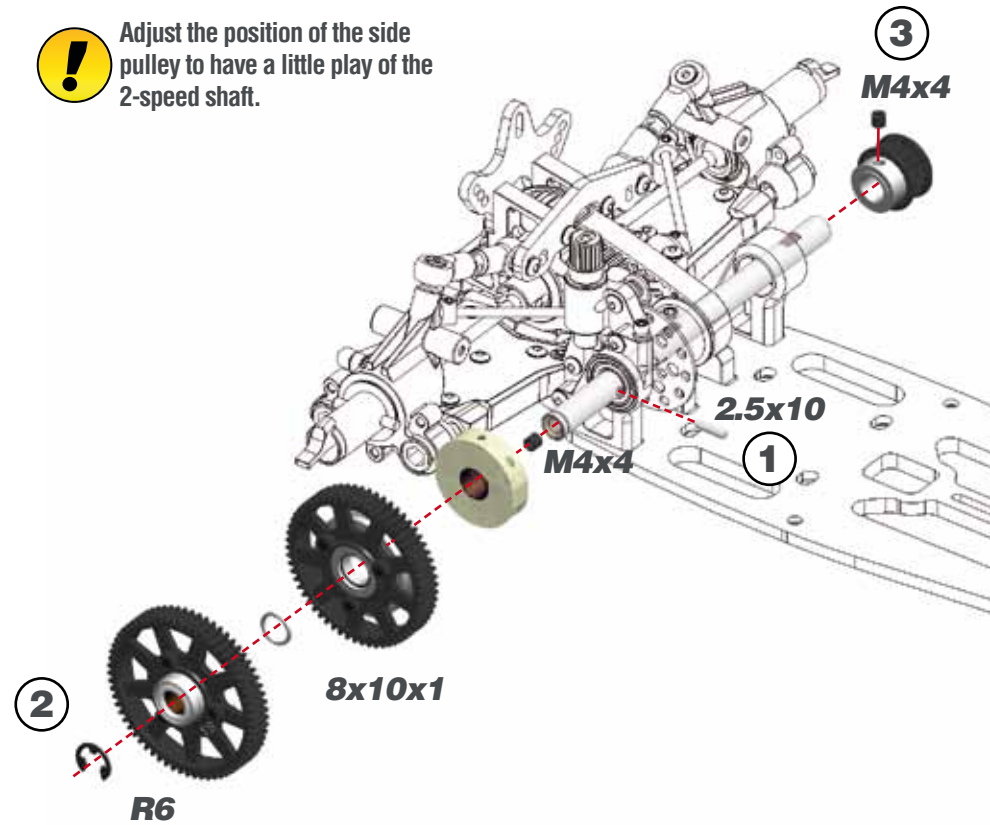

STEP 19 bag 6

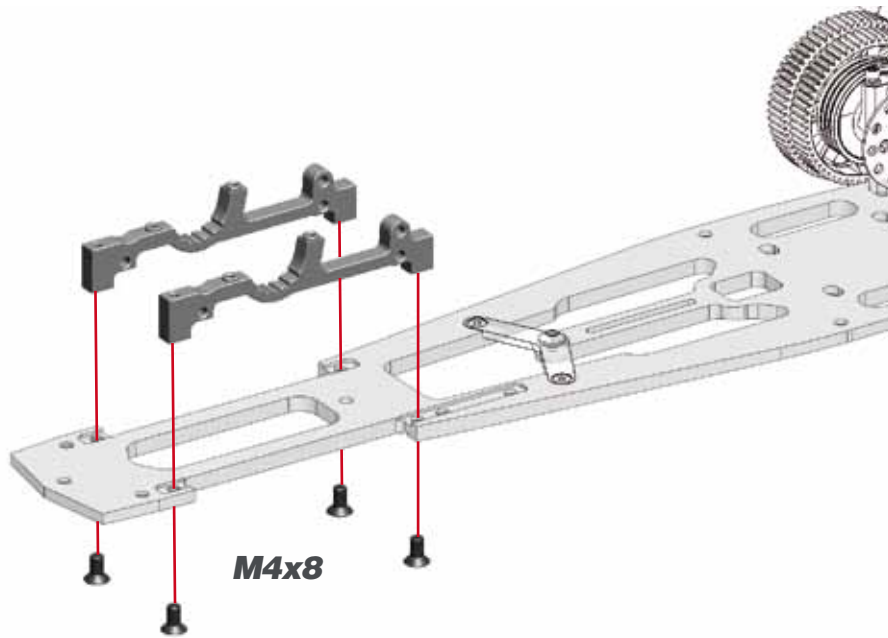

M4x8

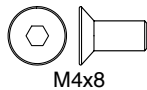

M4x8

STEP 20.1

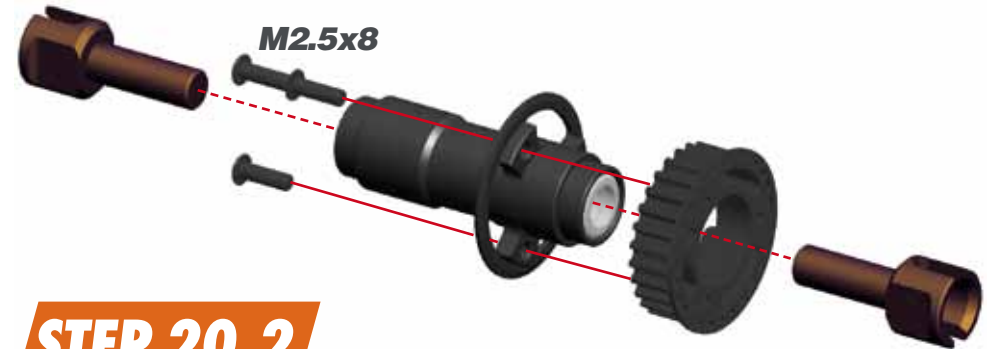

M2.5x8

STEP 20.2

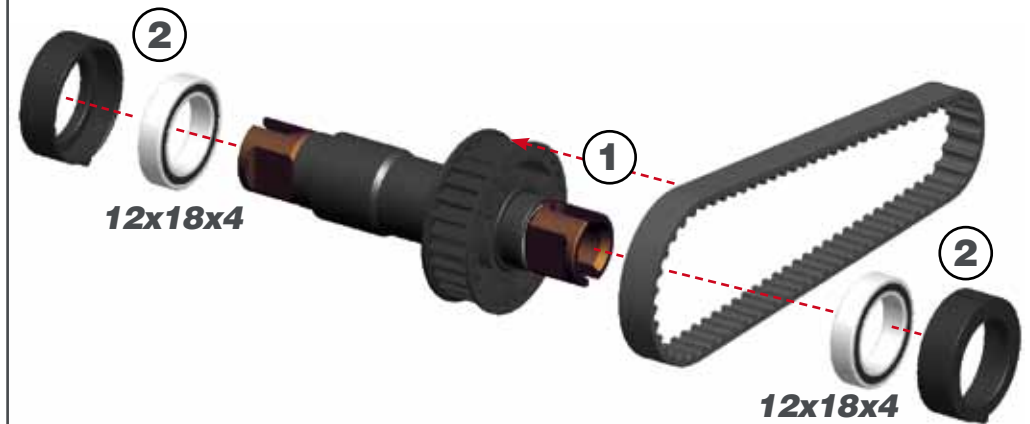

12x18x4

12x18x4

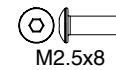

M2.5x8

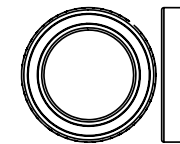

12x18x4

STEP 21

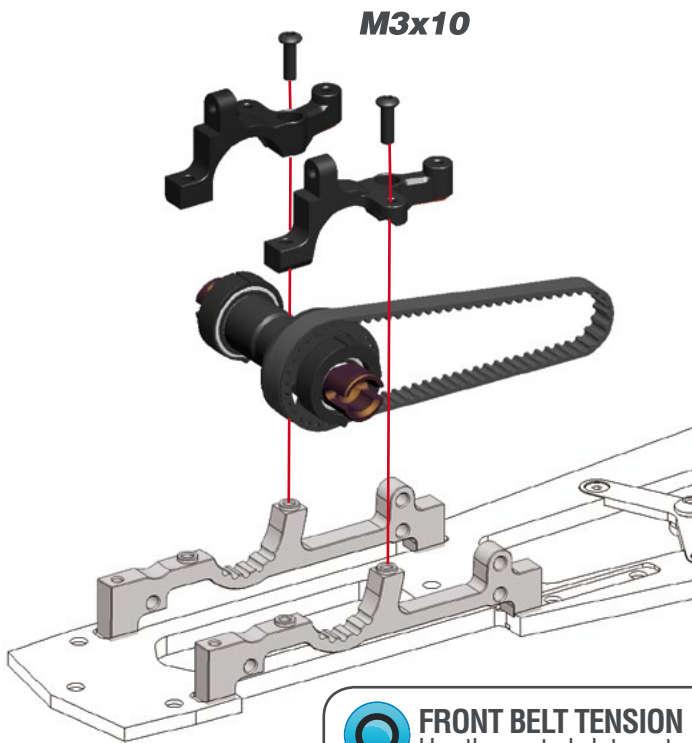

M3x10

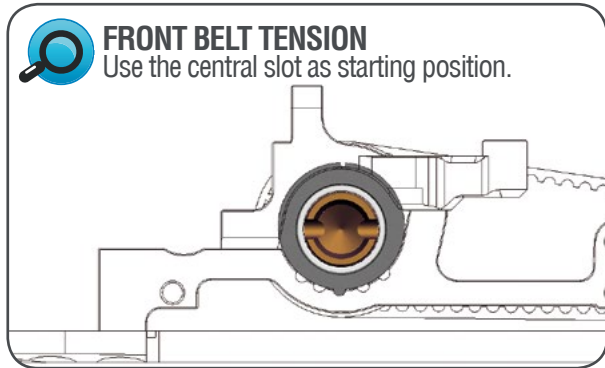

M3x10

STEP 22.1

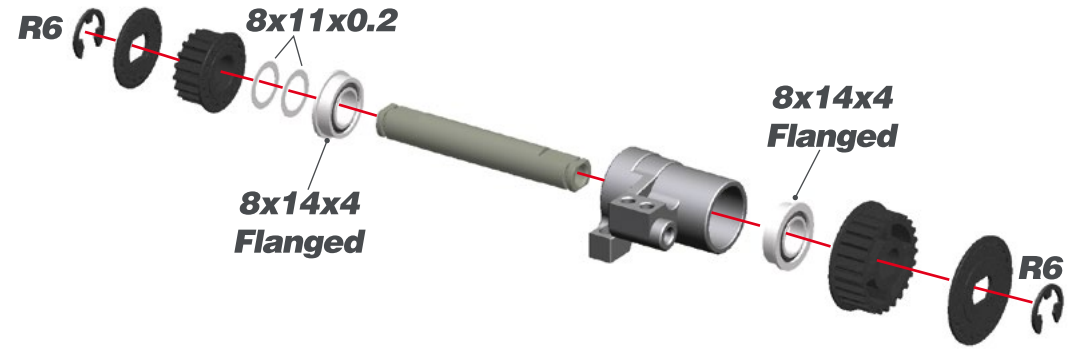

R6

8x11x0.2

8x14x4
Flanged

8x14x4
Flanged

R6

STEP 22.2

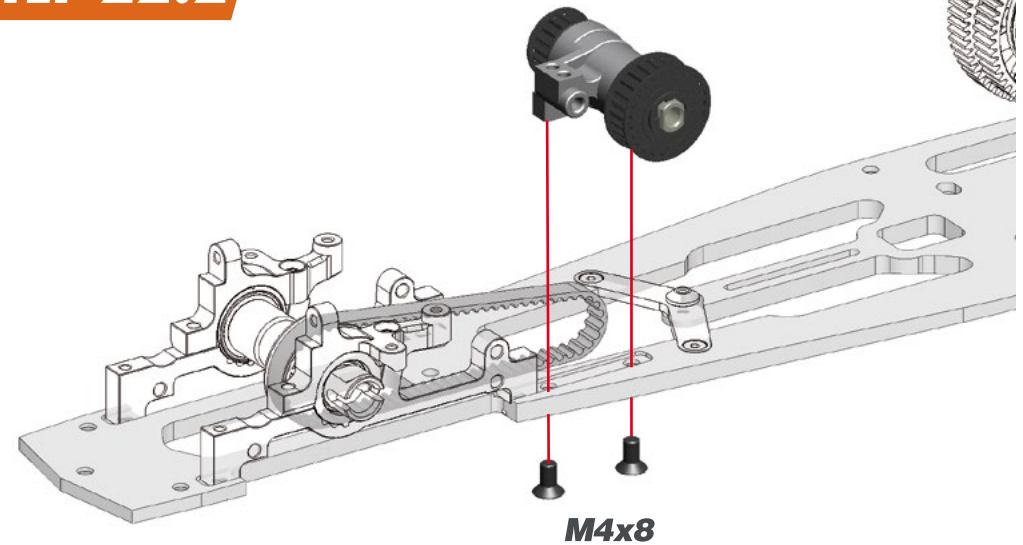

M4x8



8x11x0.2

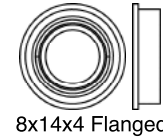

8x14x4 Flanged



R6



M4x8

STEP 23.1 bag 7

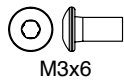
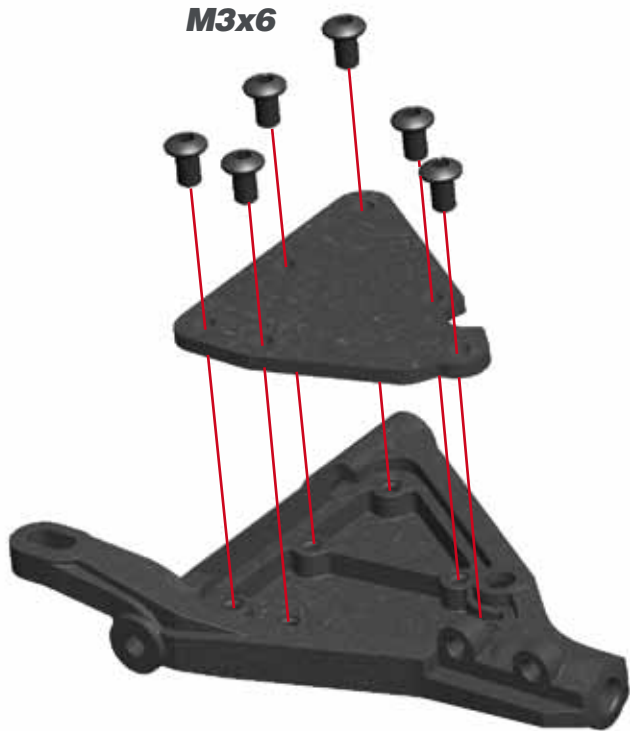

STEP 23.2

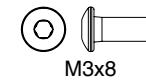
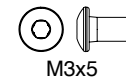
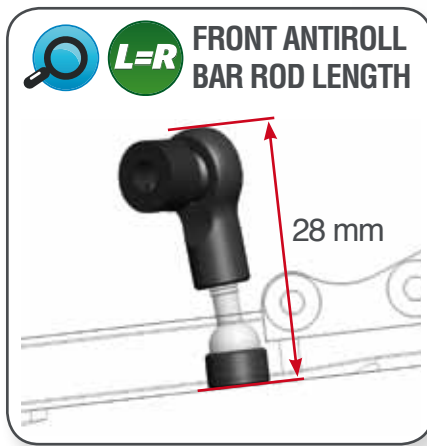

STEP 23.3

L=R FRONT LOWER SUSPENSION AND SHOCKS BRACKETS

Serpent 988 allows to move front bottom arms 3 mm in (NARROW) and out (WIDE). For maintaining same shock angle use suspension and shock brackets as shown below:

NARROW

WIDE

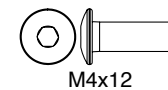
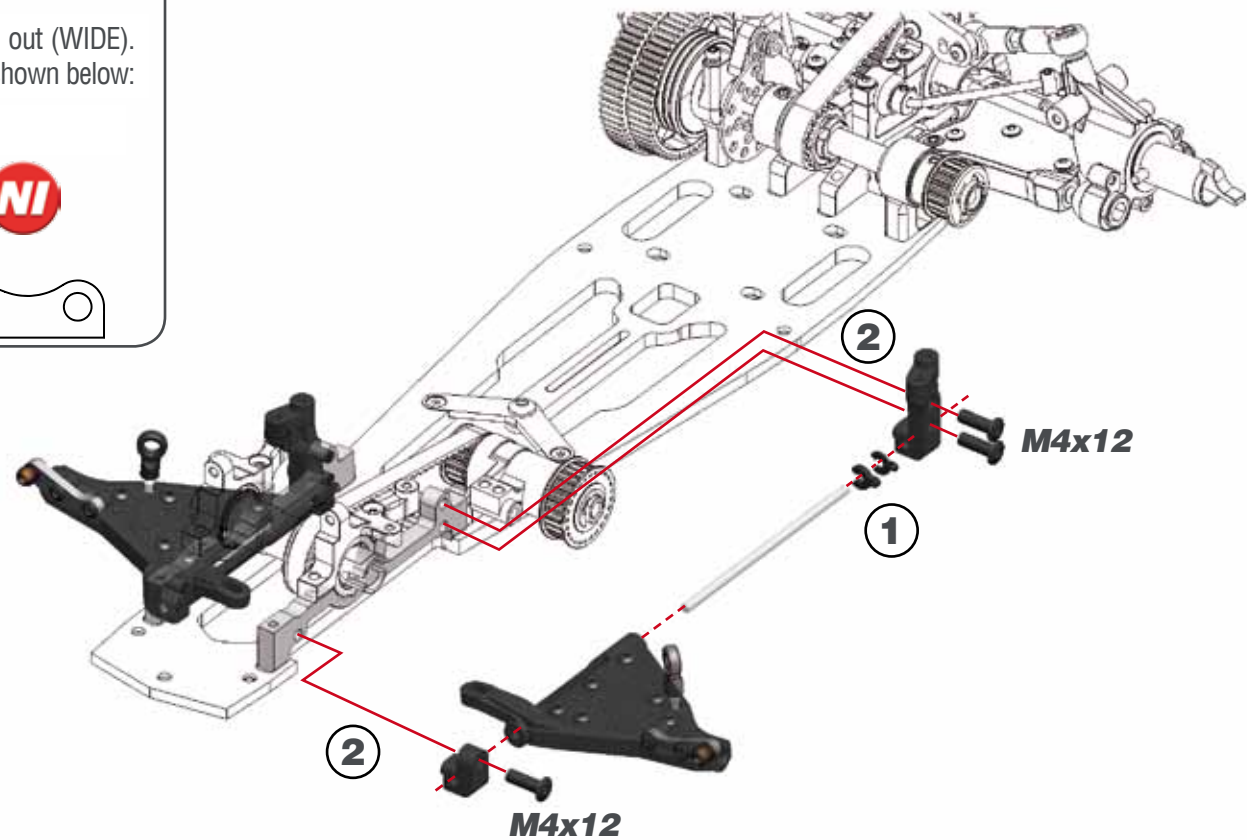
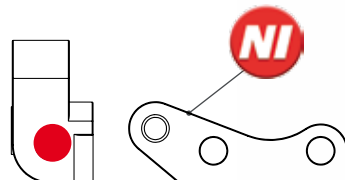
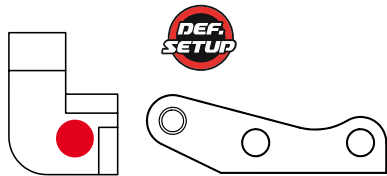

STEP 24.1

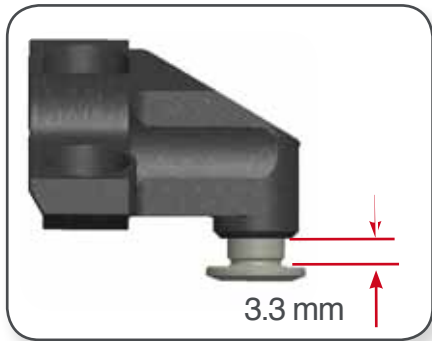
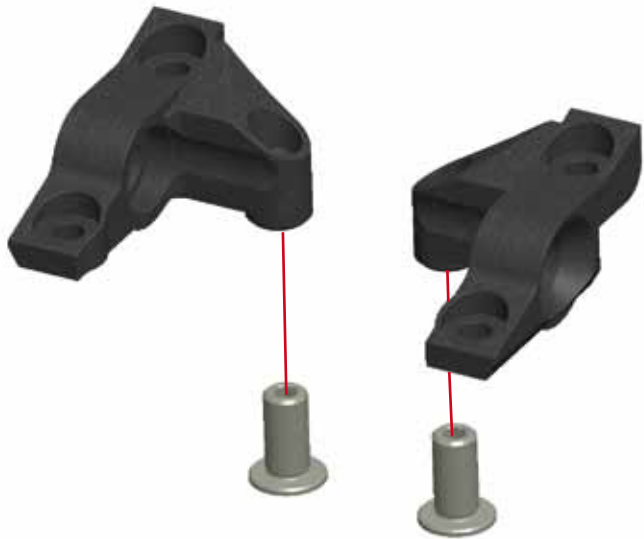

STEP 24.2



STEP 24.3

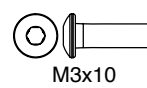
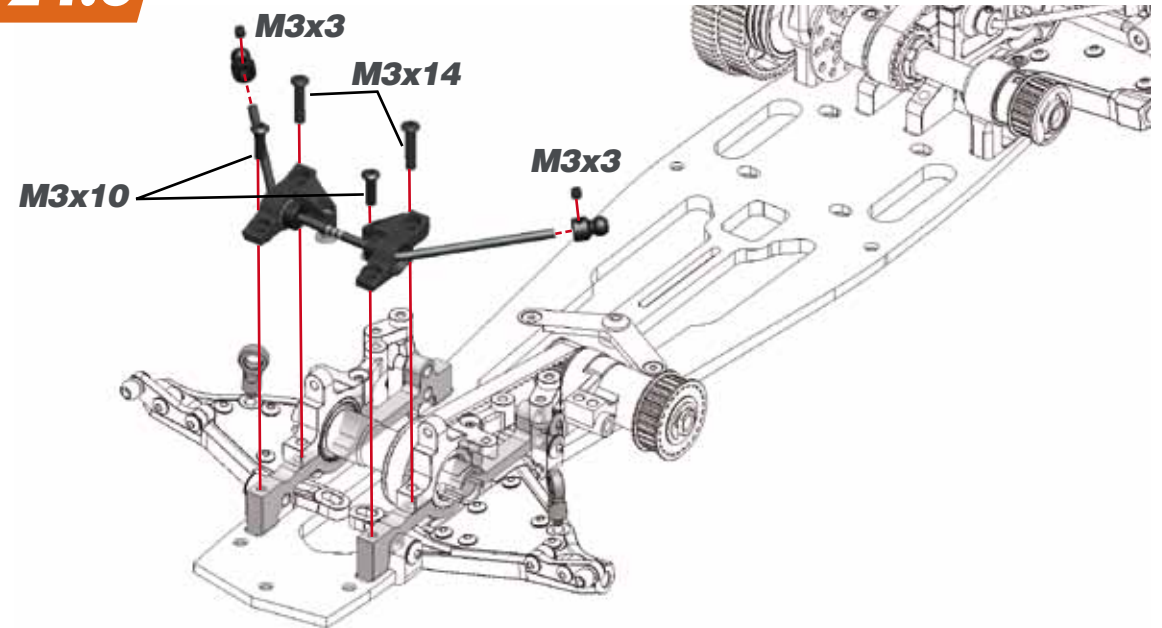

M3x10



5x8x2.5



M3x3

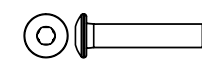

M3x14

STEP 25 bag 8

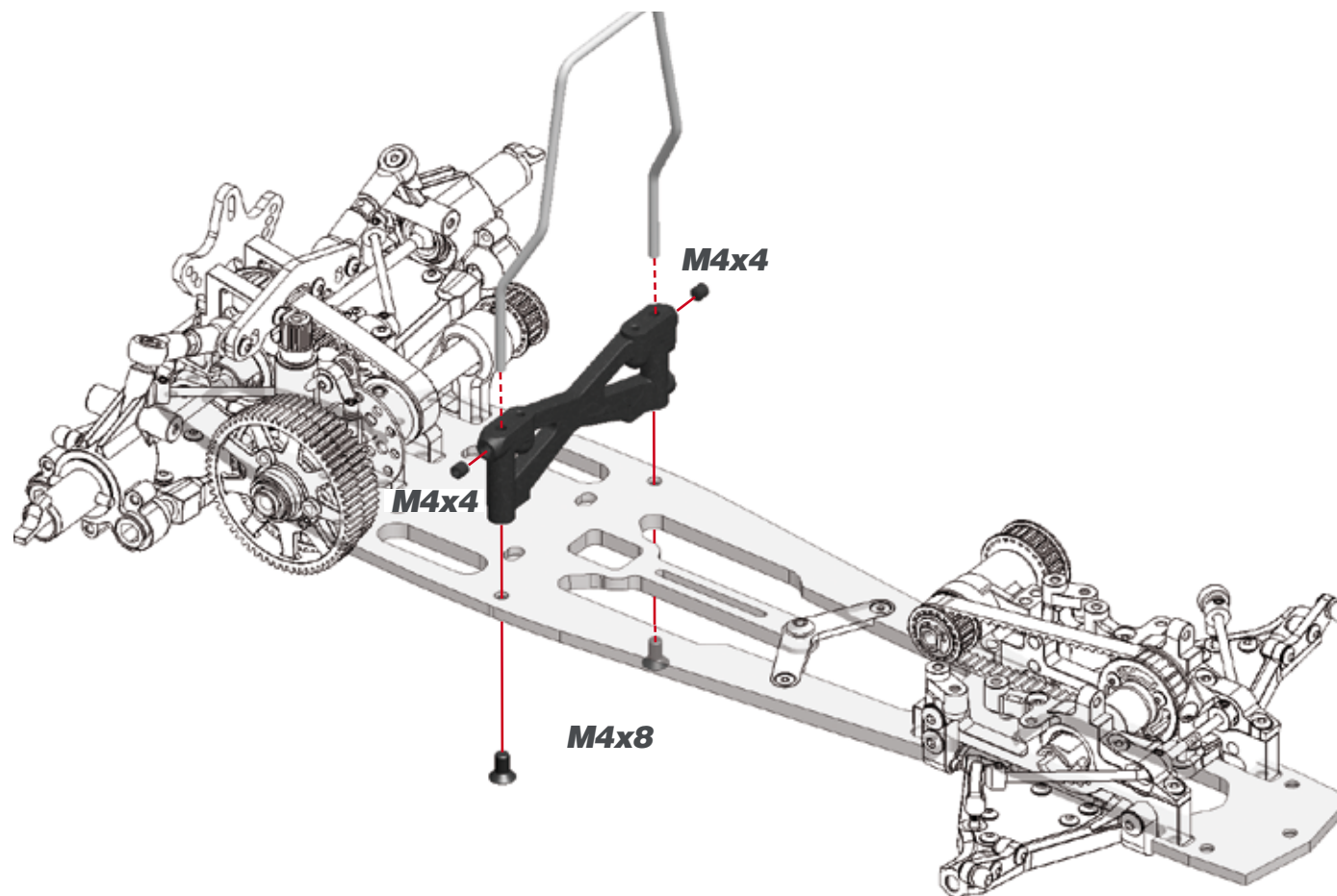

M4x4



M4x8

STEP 26.1



M3x6



STEP 26.2

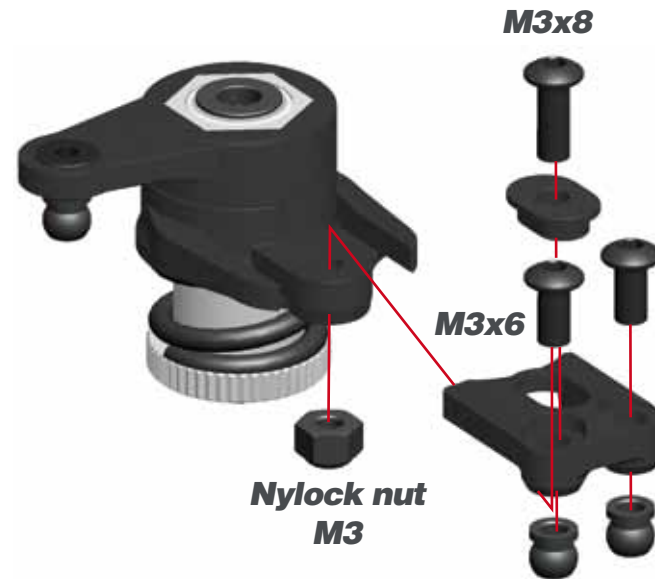

M3x8

M3x6

**Nylock nut
M3**

 Preload the servo-saver-spring 1mm.

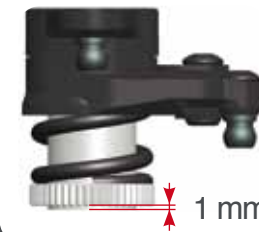

 **SERVO SAVER ACKERMANN INSERTS**

REARWARD **MID** **FORWARD**

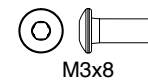
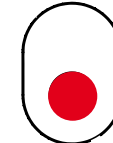
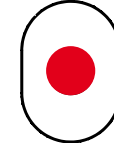
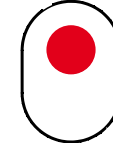

STEP 27.1



STEERING LINK LENGTH

7.5 mm

STEP 27.2

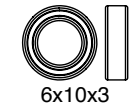
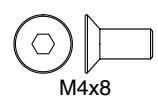
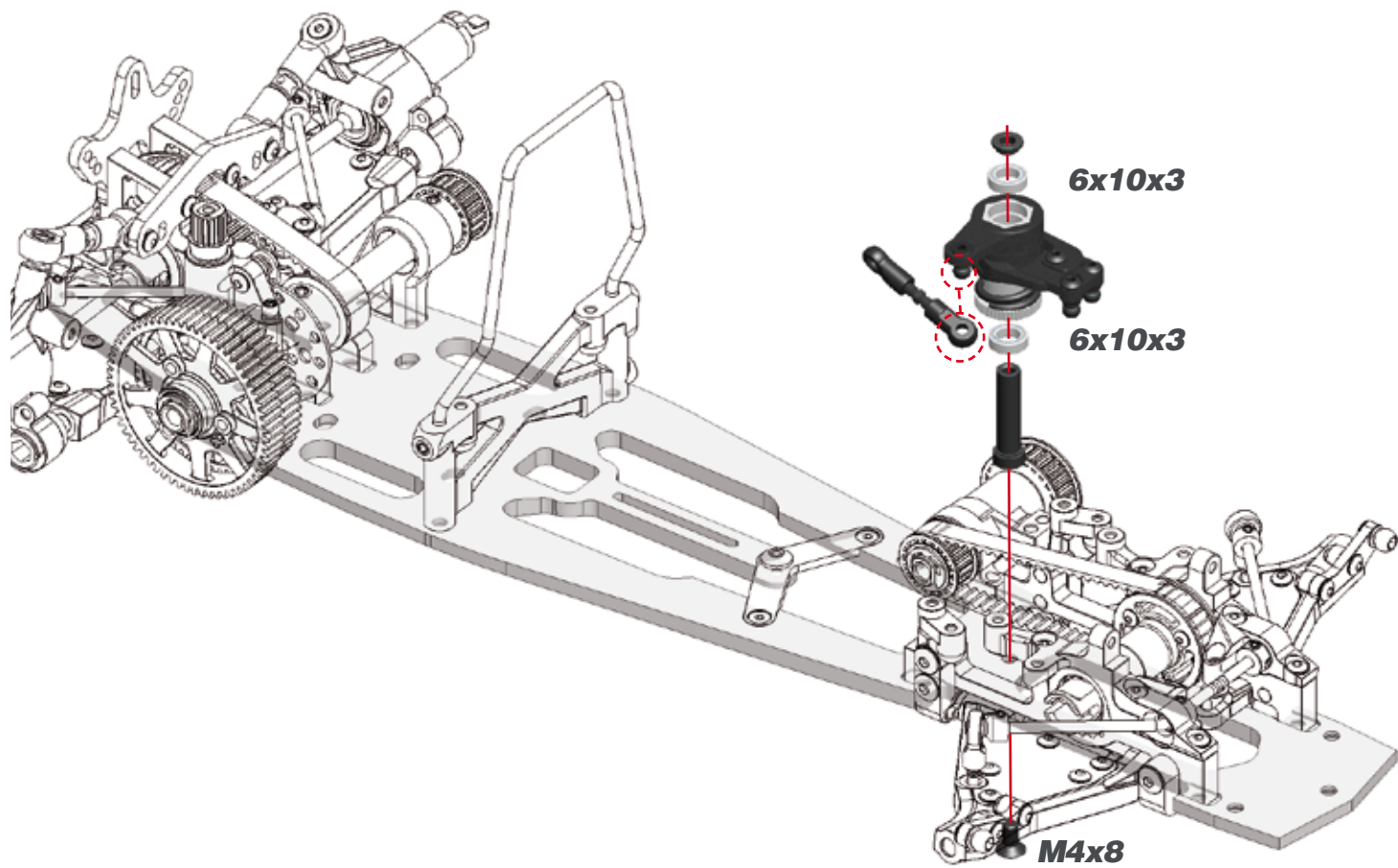

STEP 28 bag 9

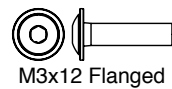
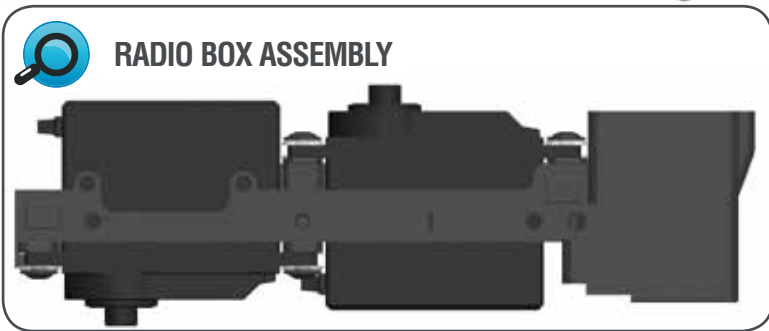
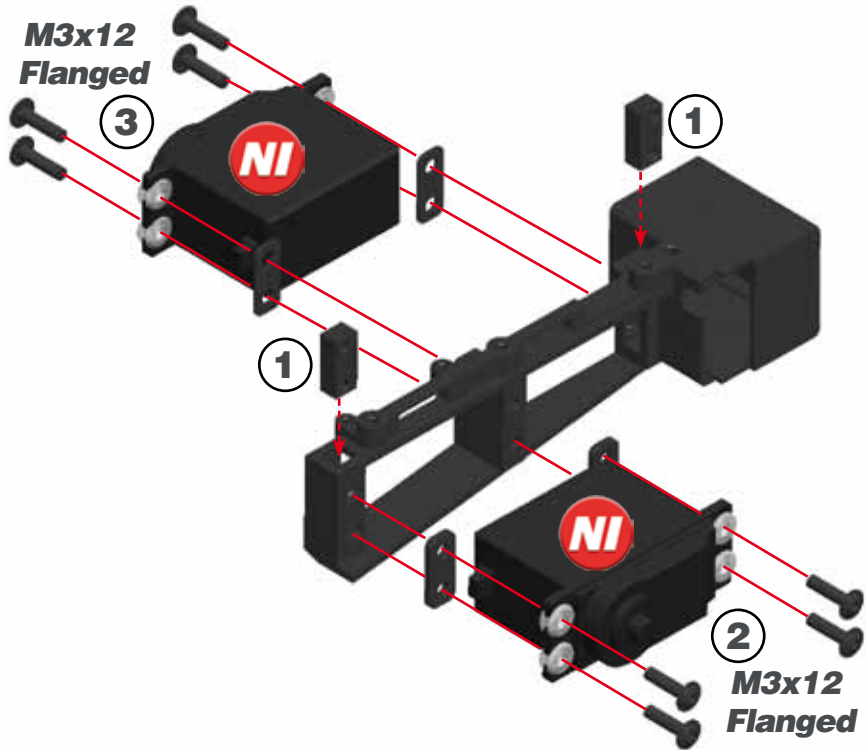

M3x12 Flanged

STEP 29

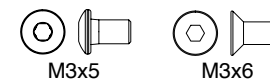
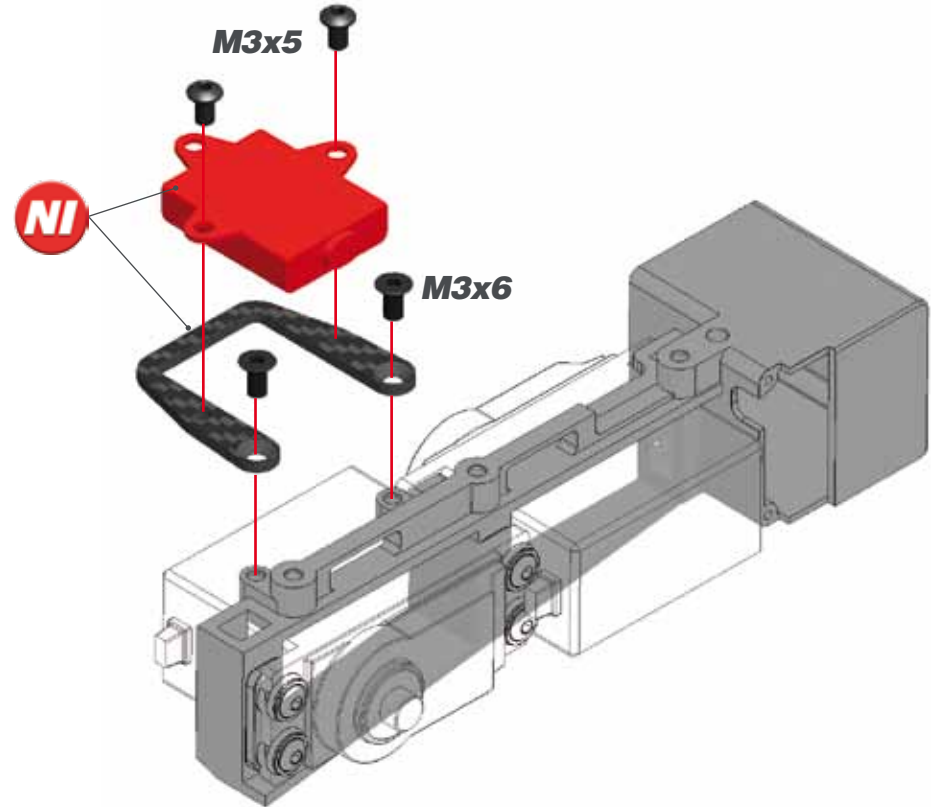

M3x5

M3x6

STEP 30

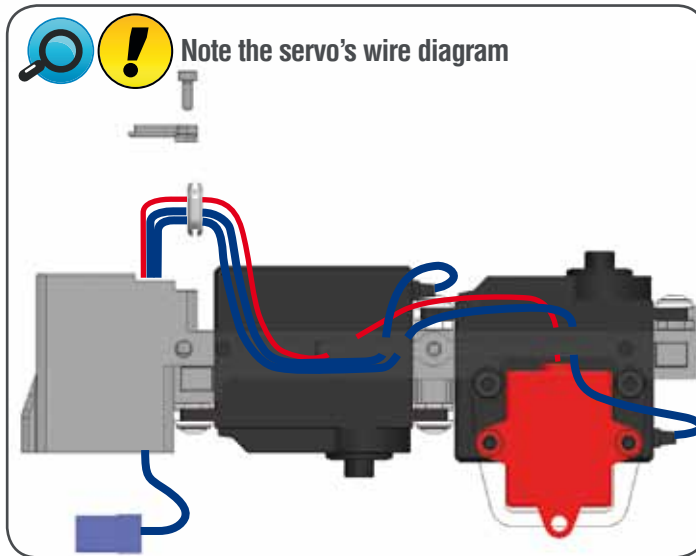
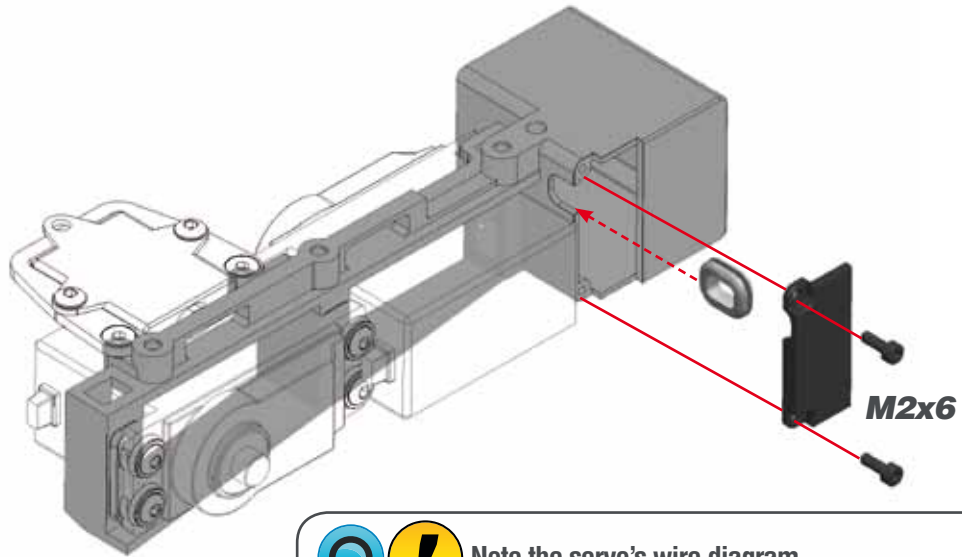

M2x6

STEP 31

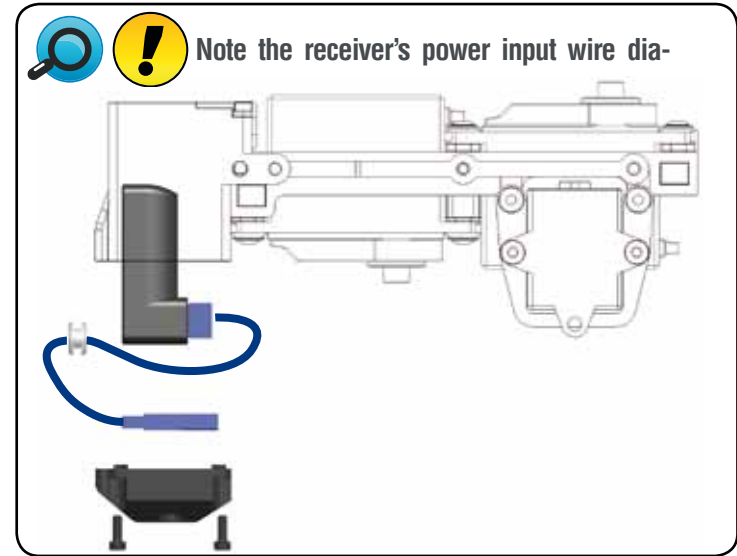
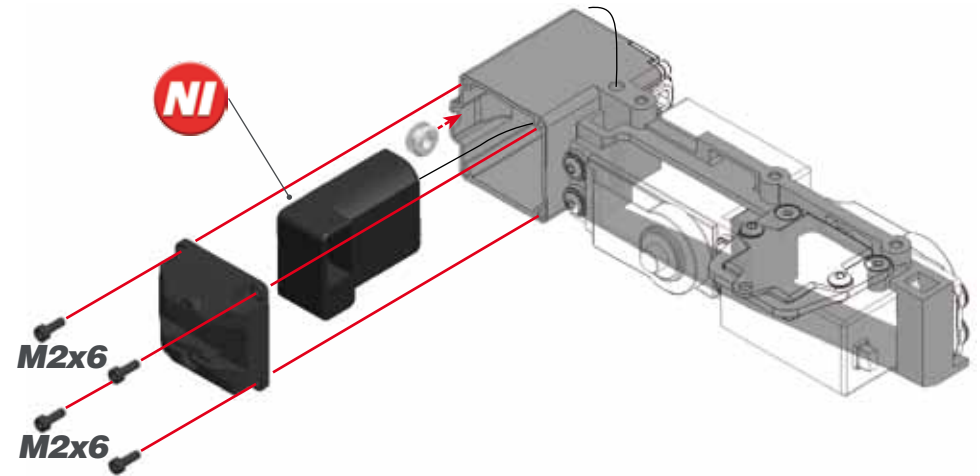

M2x6

STEP 32

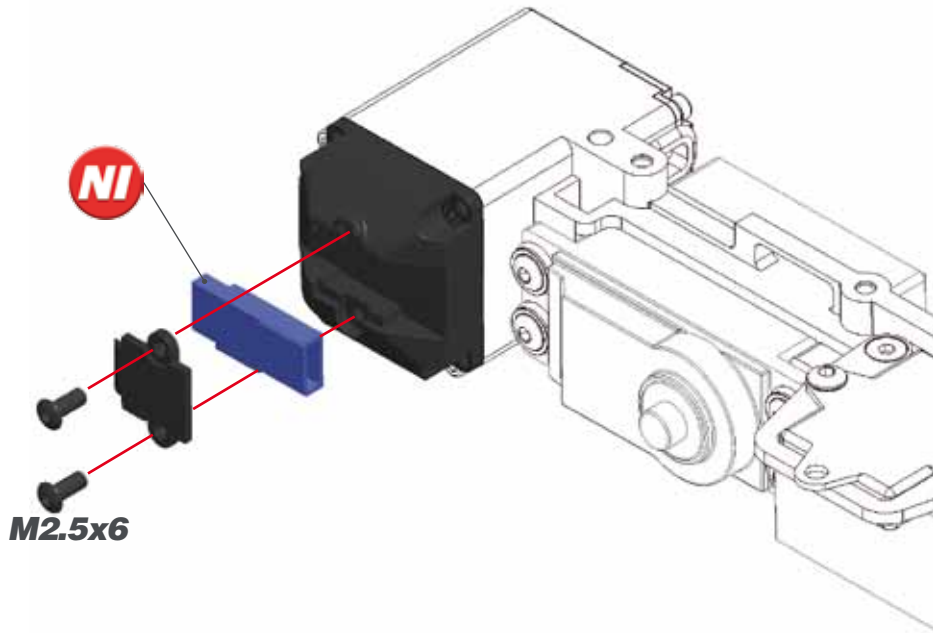

M2.5x6

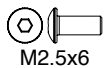

M2.5x6

STEP 33

! Check how many teeth your servo spline has (23, 24 or 25) and use the right levers.

! Note correct pivot ball type.



! Note correct pivot ball type.



M3x6

A

M3x5

M3x8

B

! A: Note orientation of the throttle servo lever.

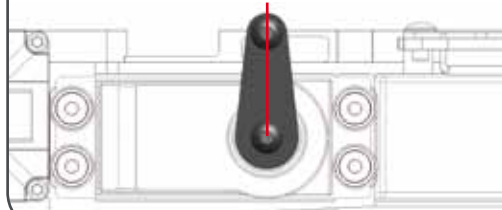

! B: Note orientation of the steering servo lever.

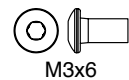

M3x6



M3x5

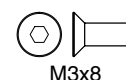

M3x8

STEP 34.1

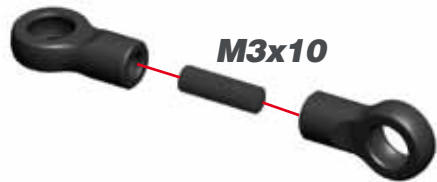

STEP 34.2

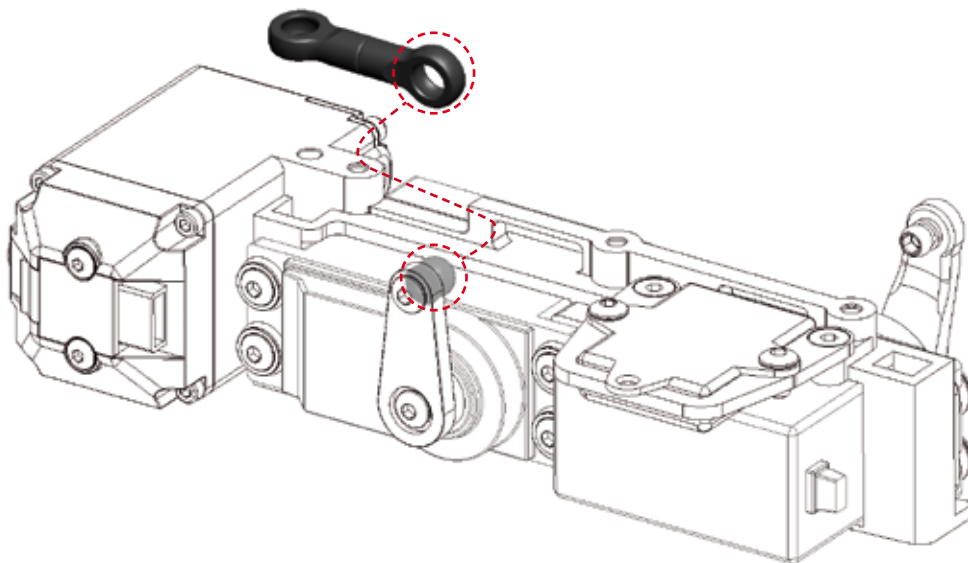

STEP 35 bag 10

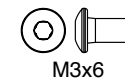
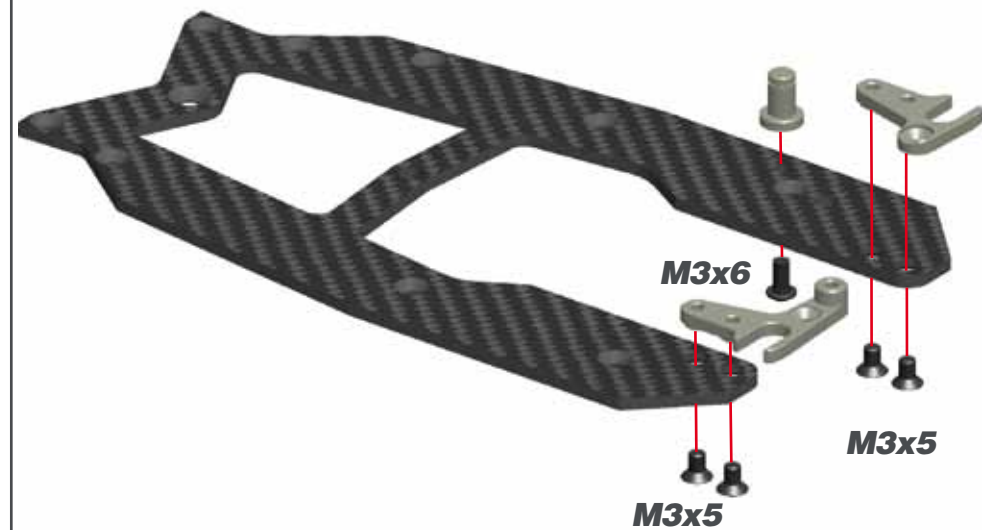

STEP 36.1



STEP 36.2

! Note that the front grommet must be cut 1mm as shown in the picture below.

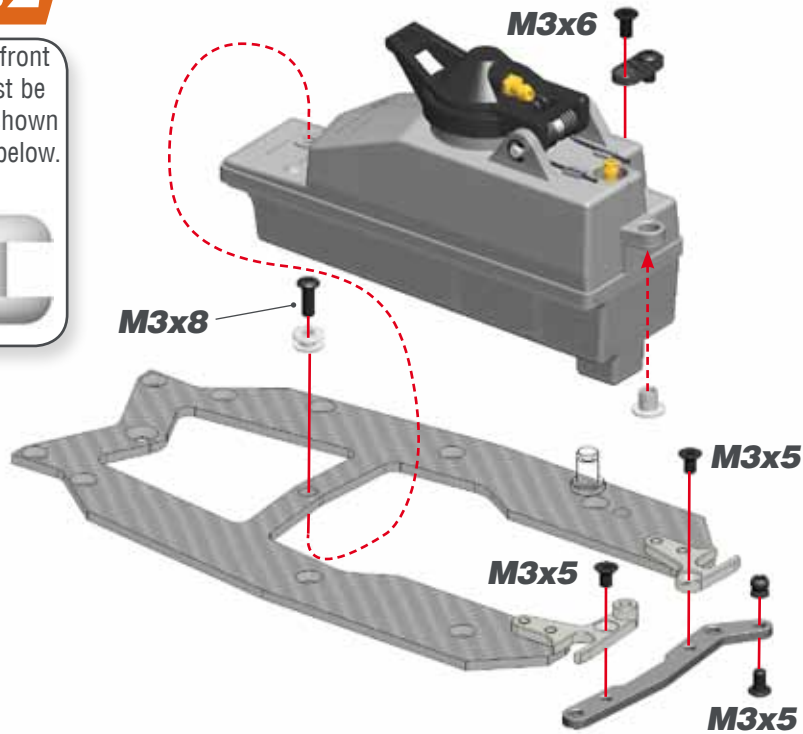

STEP 37

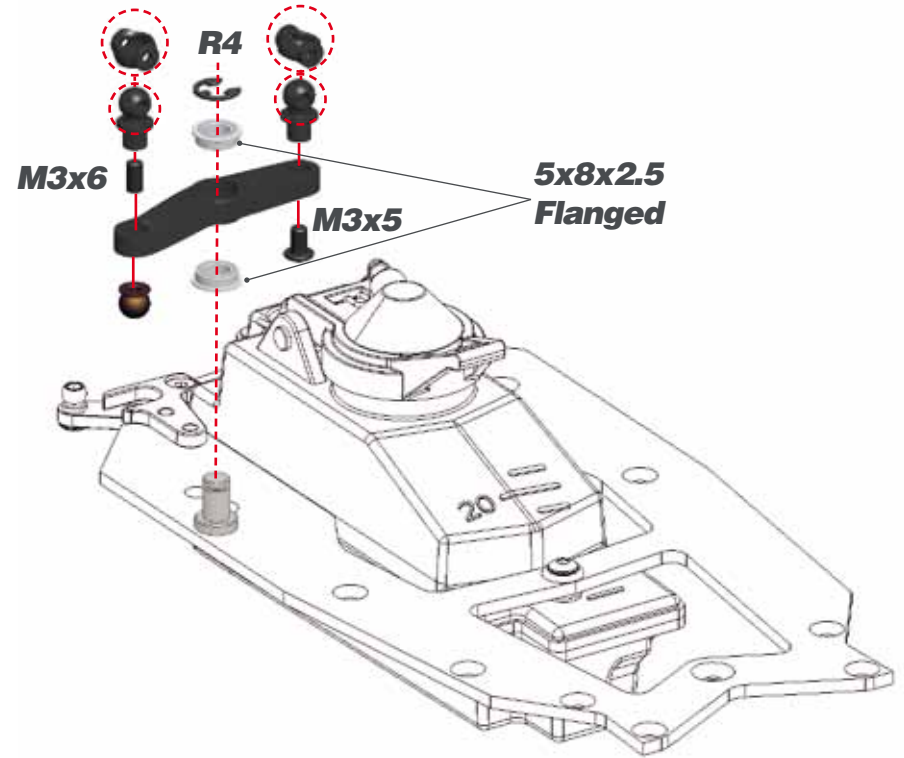

STEP 38

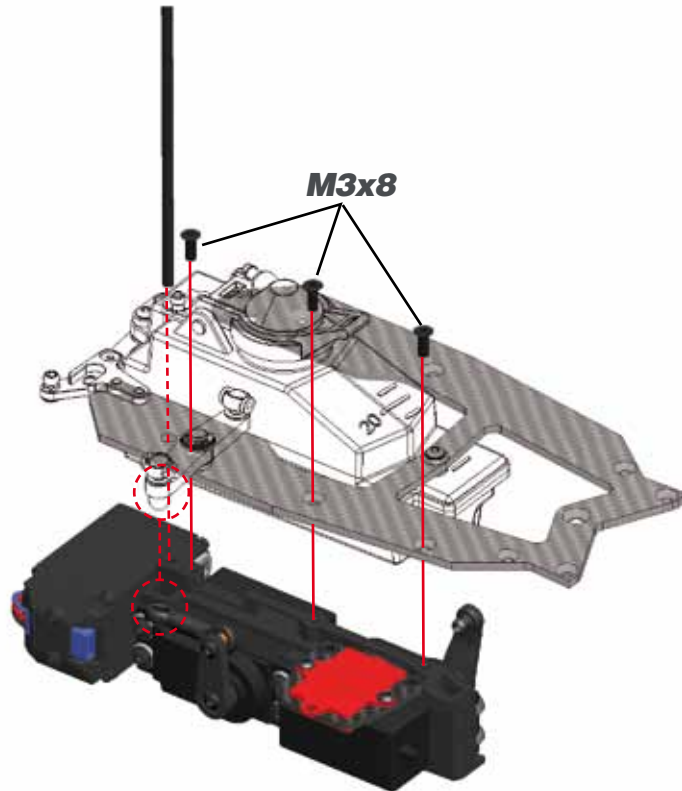

M3x8

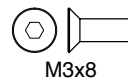

STEP 39.1

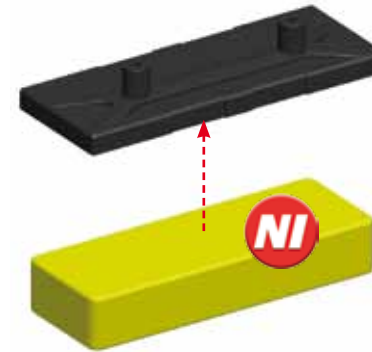

! Use tape to mount the battery to the plastic support.

STEP 39.2

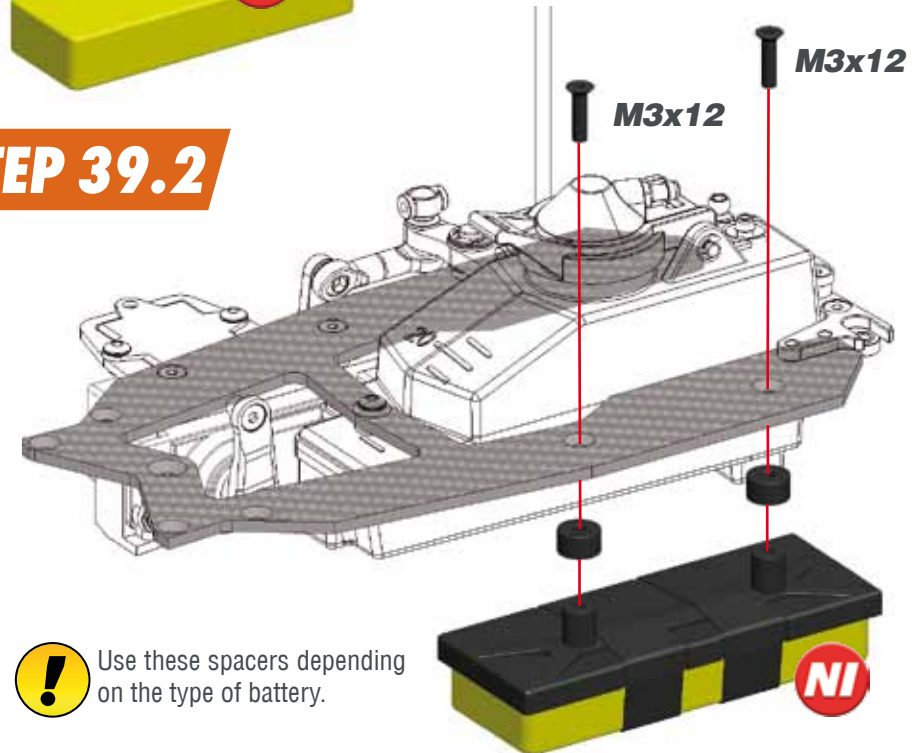

M3x12

M3x12

! Use these spacers depending on the type of battery.

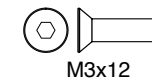

STEP 40

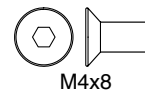
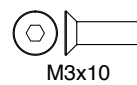
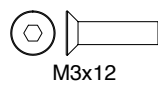
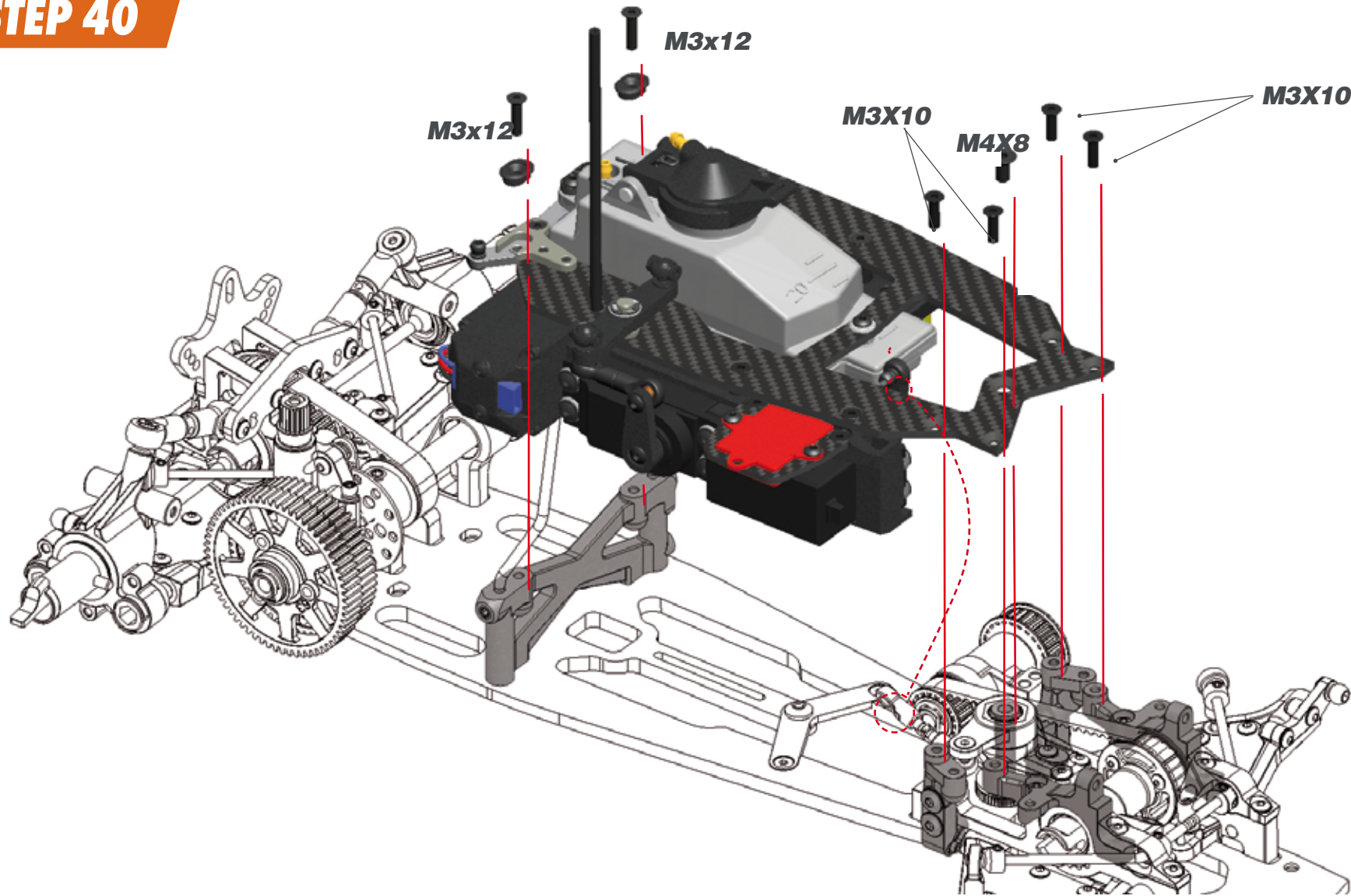

STEP 41 bag 11

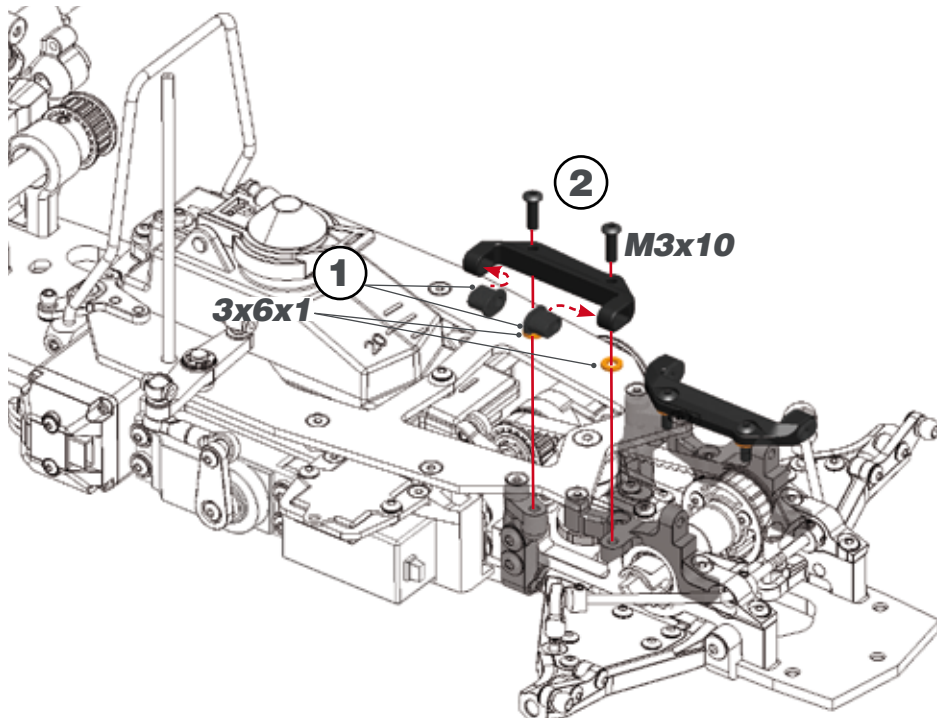

L=R FRONT SUSPENSION INSERTS CHART

INSIDE		MID		OUTSIDE	
RIGHT	LEFT	RIGHT	LEFT	RIGHT	LEFT

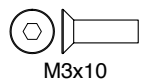

STEP 42

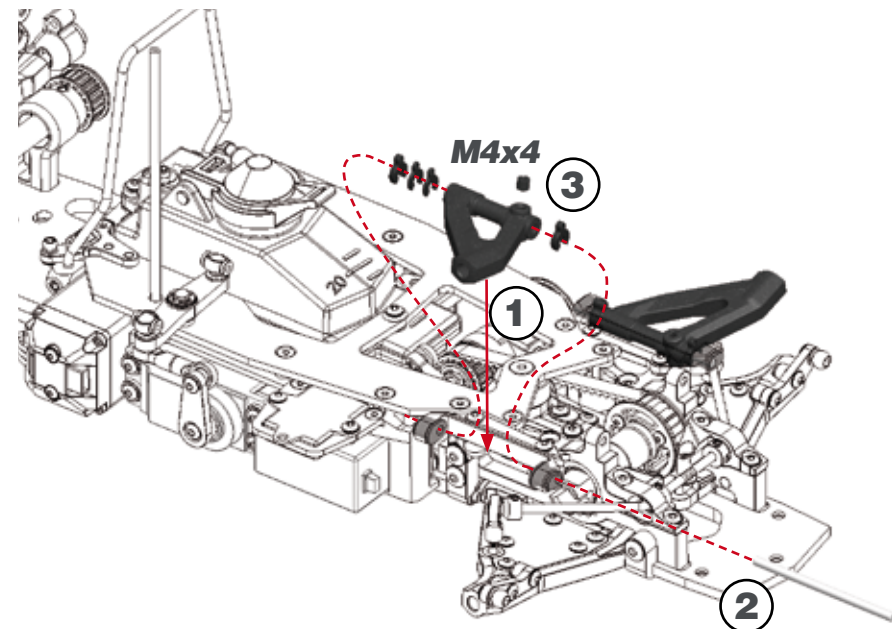

L=R FRONT CASTER DEFAULT SPACERS

DEF. SETUP

2mm 1mm 2mm



STEP 43.1

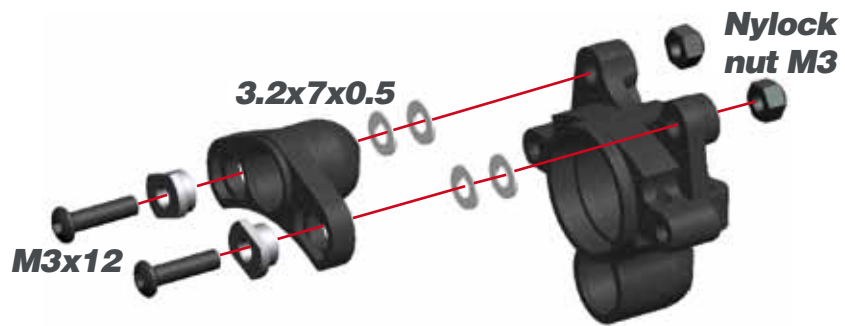

STEP 43.2

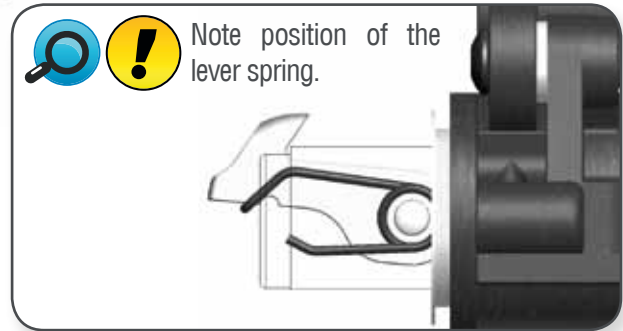
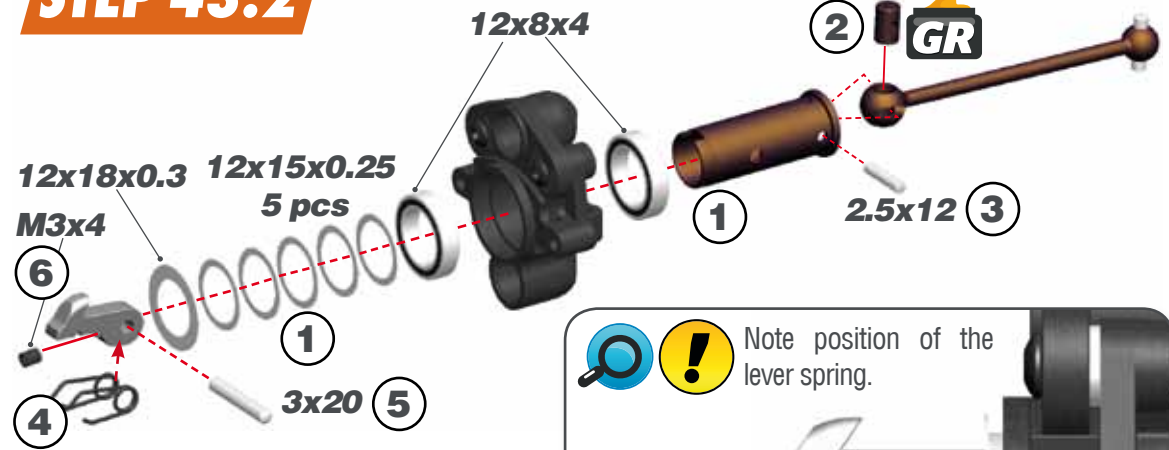

STEP 43.3

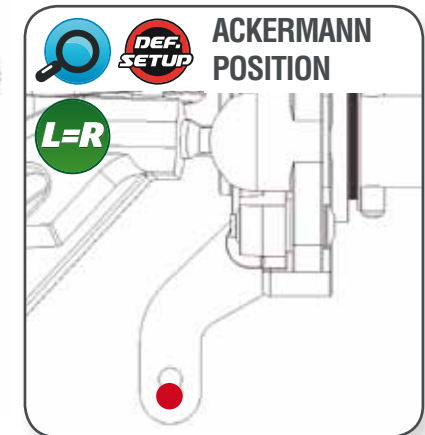
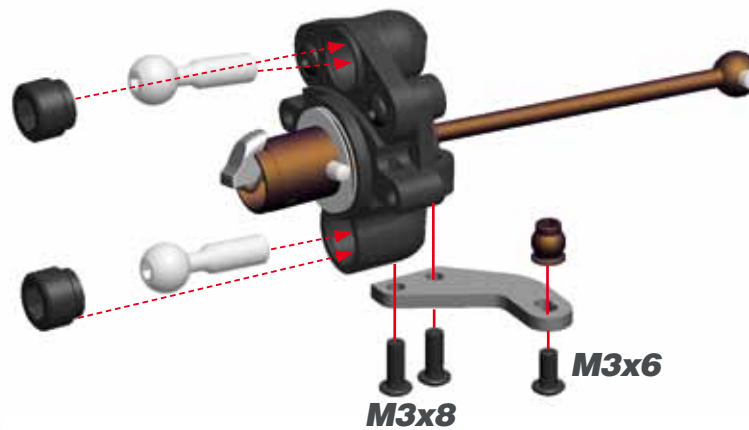

	STEERING BLOCK INSERTS CHART		
	LEADING	NEUTRAL <small>DEF. SETUP</small>	TRAILING
RIGHT			
LEFT			

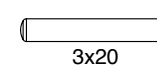
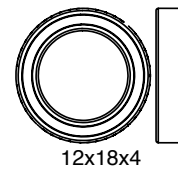
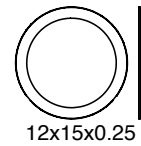
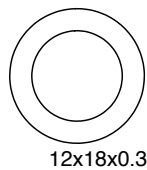
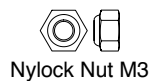
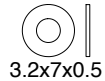
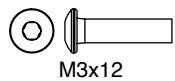

STEP 44

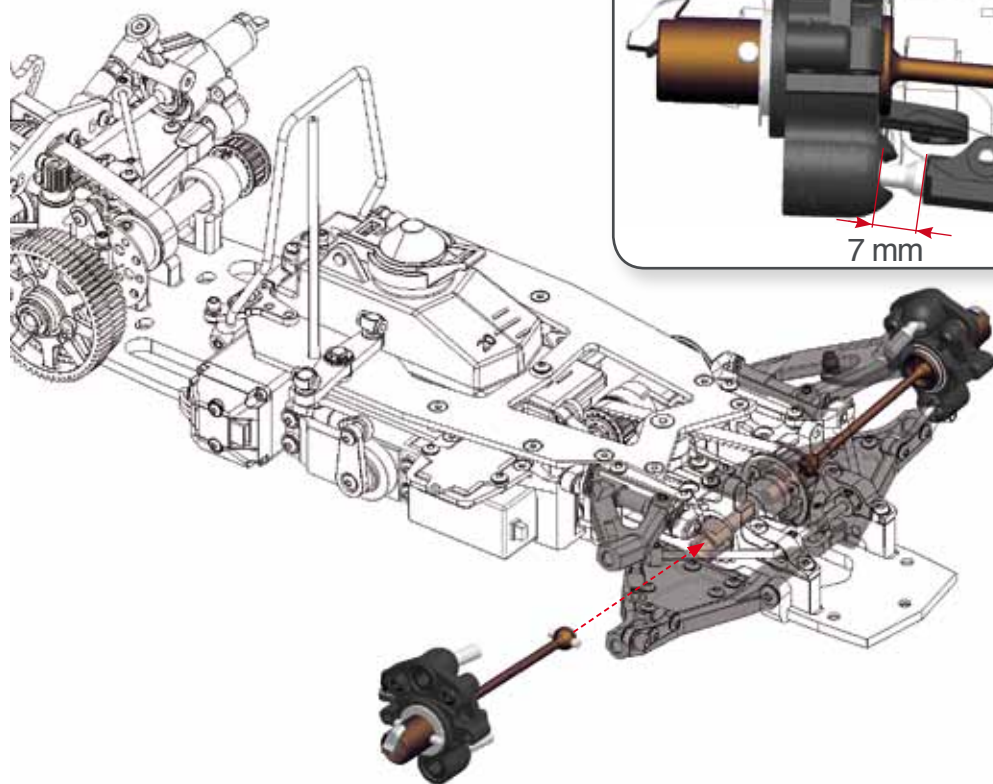
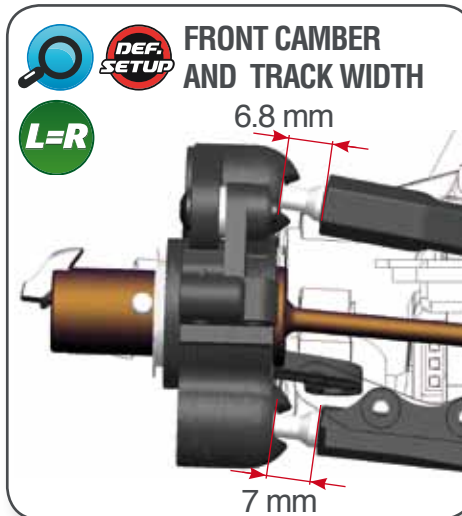

STEP 45

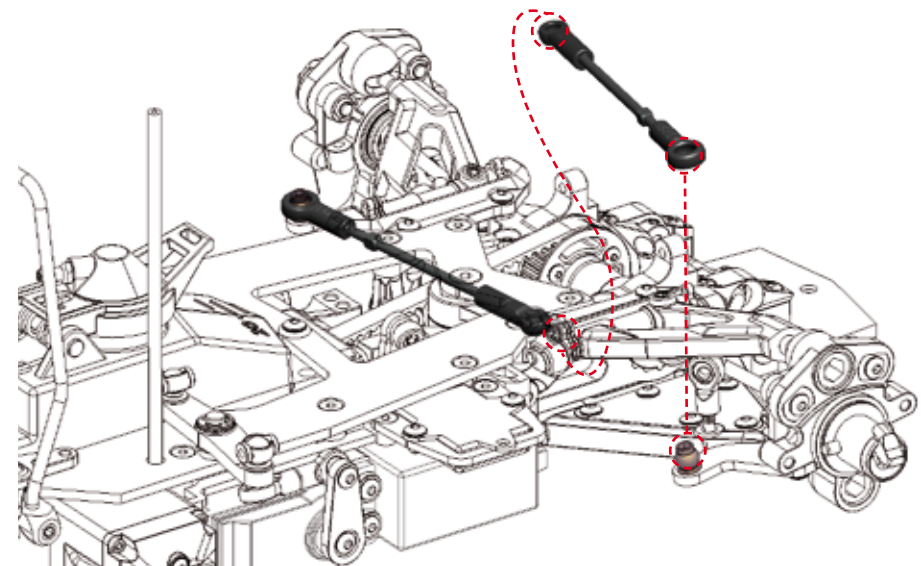
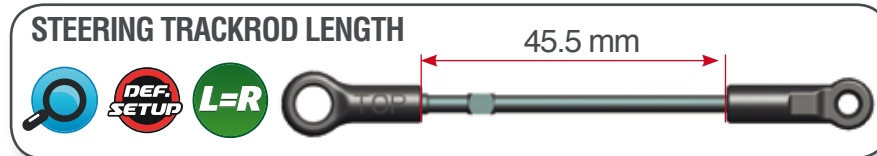

STEP 46.1 shockbag



Use some silicone oil during the assembly.

SO

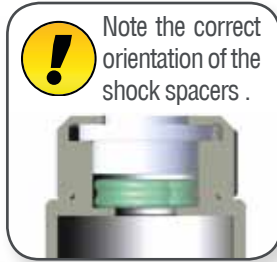

Note the correct orientation of the shock spacers.

STEP 46.2



1 Insert the o-ring inside the spring collar.

2



Note the correct position of the o-ring.

STEP 47.1



For the correct piston holes please check the default setupsheet.



STEP 47.2

SO

Use some silicone oil during the assembly.

FRONT



R2.3

SO

Use some silicone oil during the assembly.

REAR



R2.3

STEP 48.1

Push the shock top and the membrane into the shock cap.



STEP 48.2

1- Fill up with silicone oil fully using the silicone oil supplied in the kit. For the correct cst value please check the default setupsheet.

2- Extend the shockrod fully

3- Move the shockrod slowly up and down to let ALL air bubbles escape.

4- Close top only 3/4.

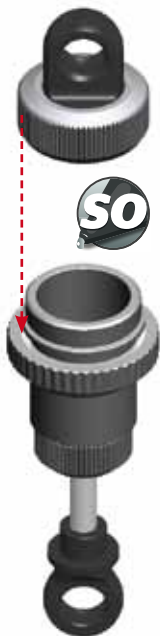

STEP 48.3

1-Bleed: push the shockrod all the way in slowly, to allow excessive oil to escape.

2- Close completely the shock cap.



SHOCKS LENGTH:

Measure the shock length fully extended.

FRONT

14 mm

REAR

14.5 mm

STEP 49

Assemble the spring and spring-cup (align correctly) to complete the shock.

FRONT

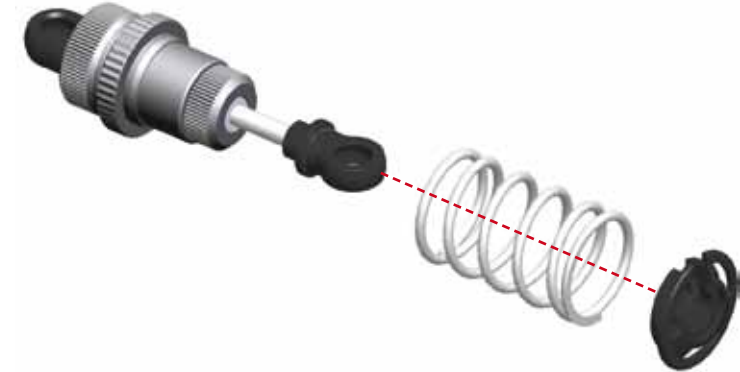

REAR

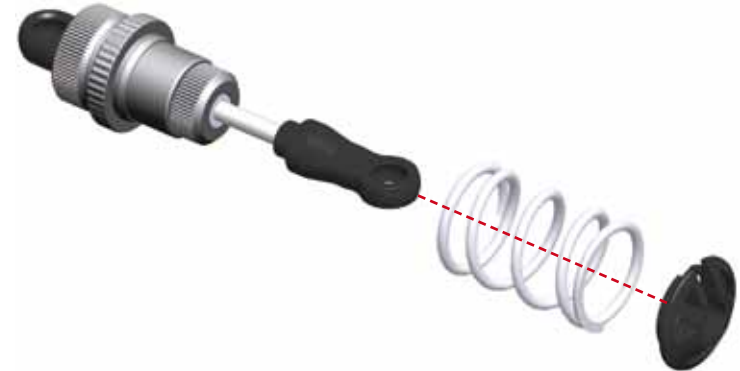

STEP 50 bag 12

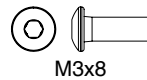
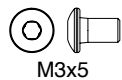
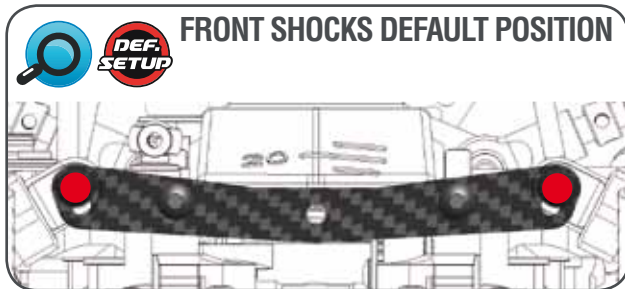
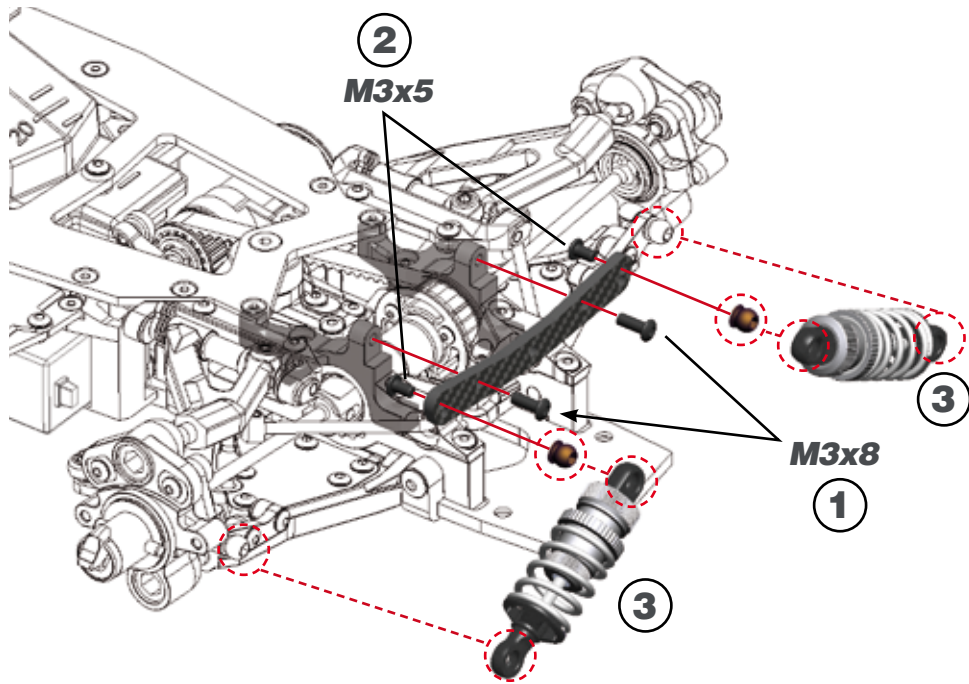

STEP 51

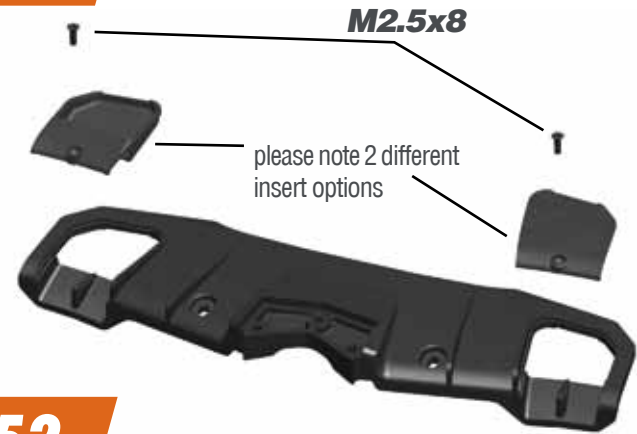

STEP 52

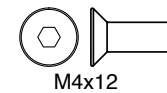
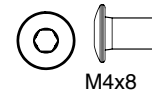
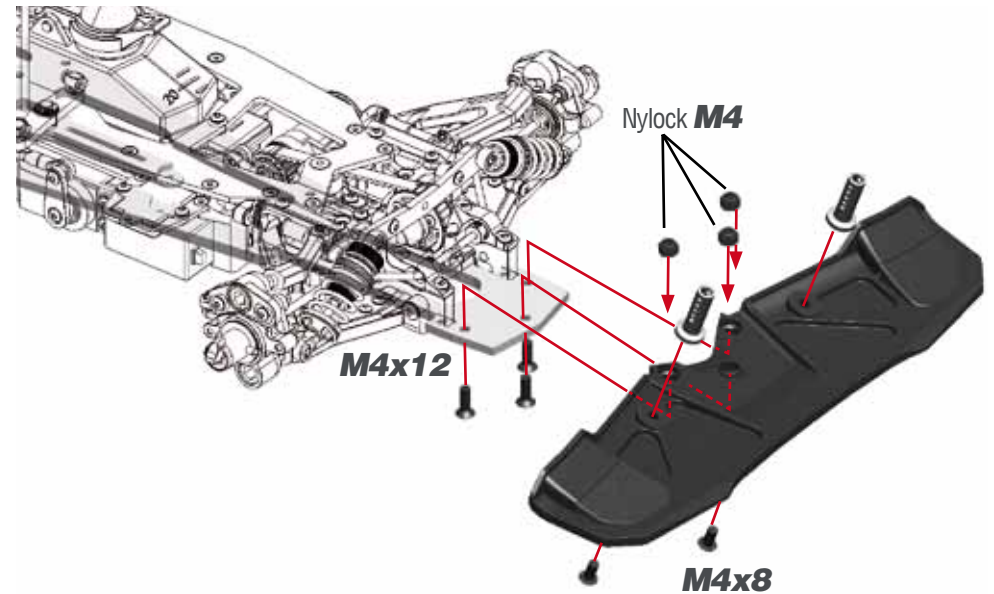

STEP 53

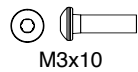
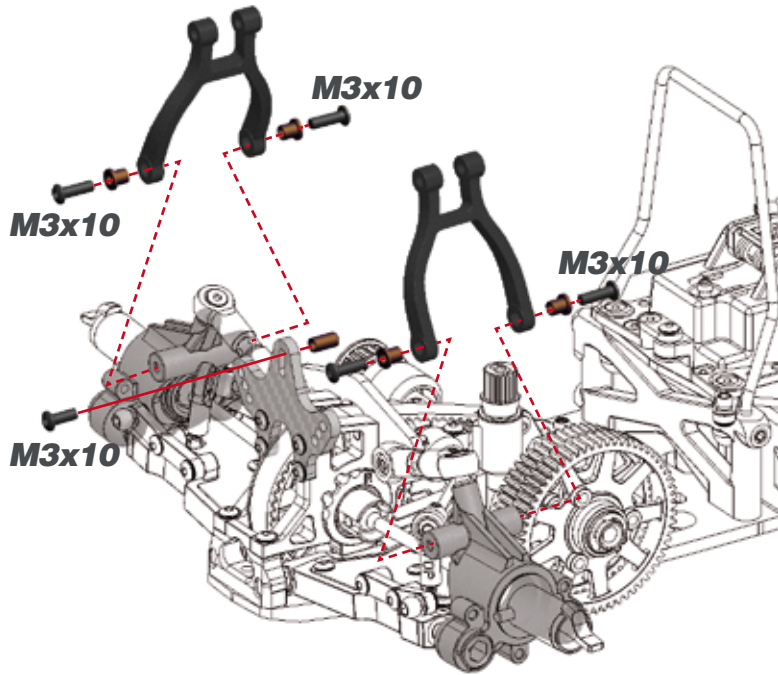

STEP 54

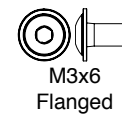
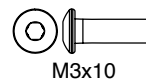
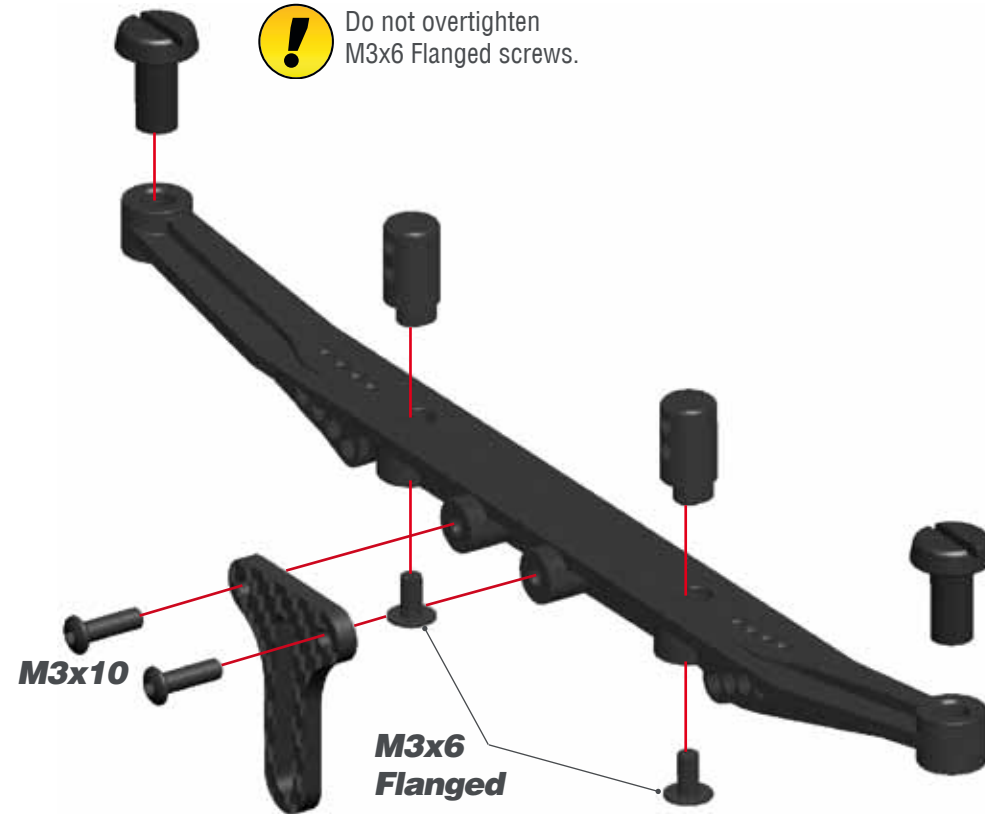

STEP 55

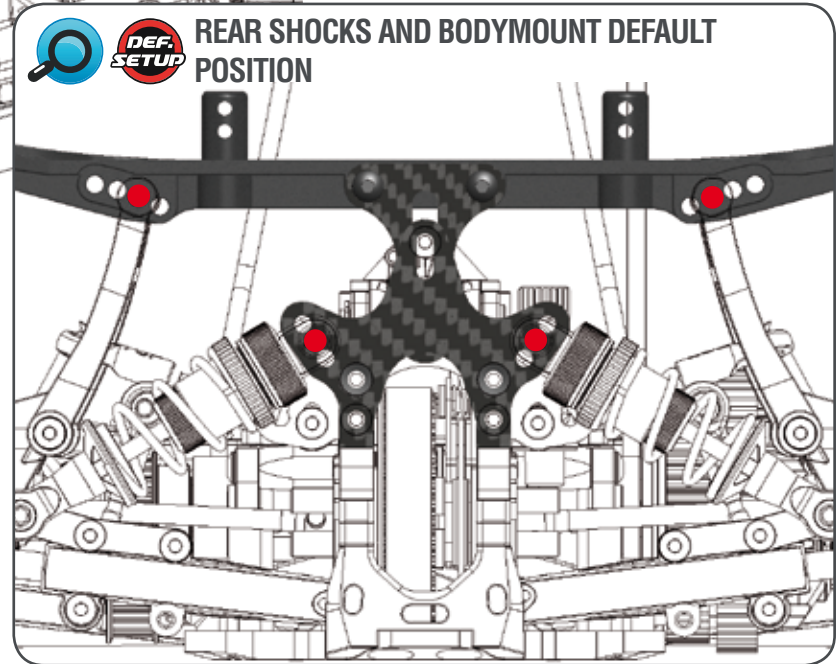
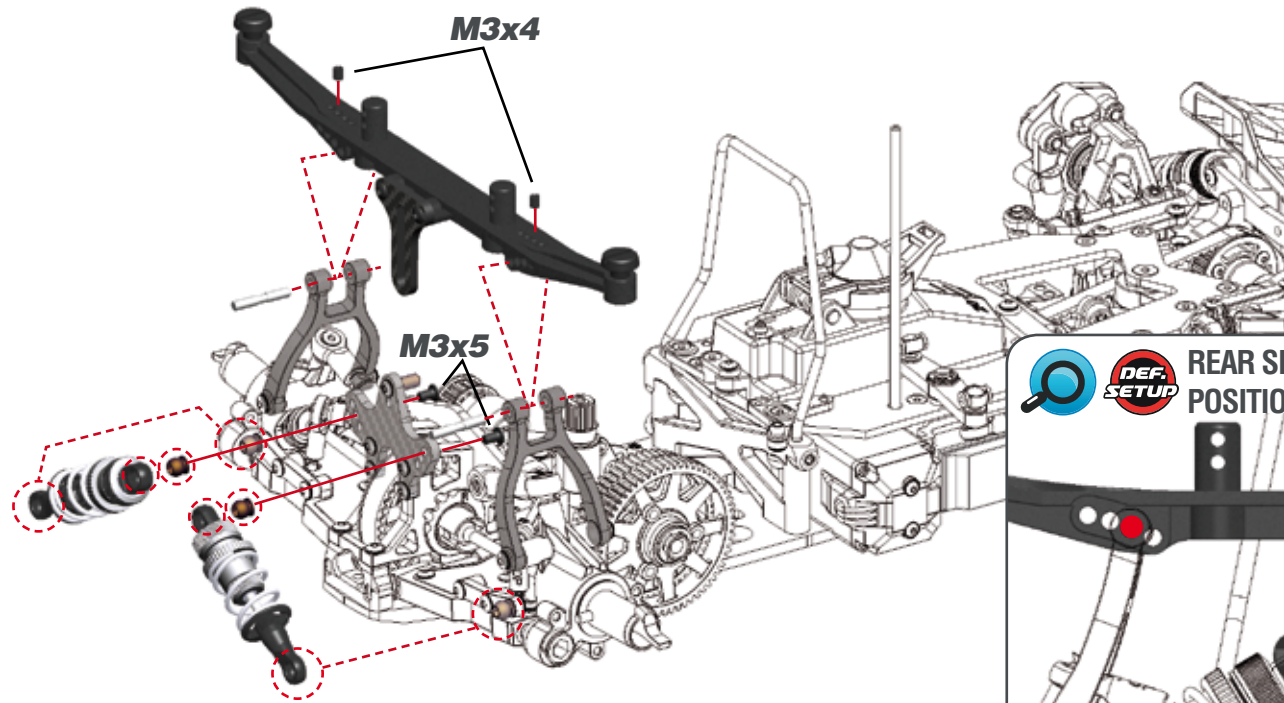

M3x4



M3x5

STEP 56.1 clutchbag

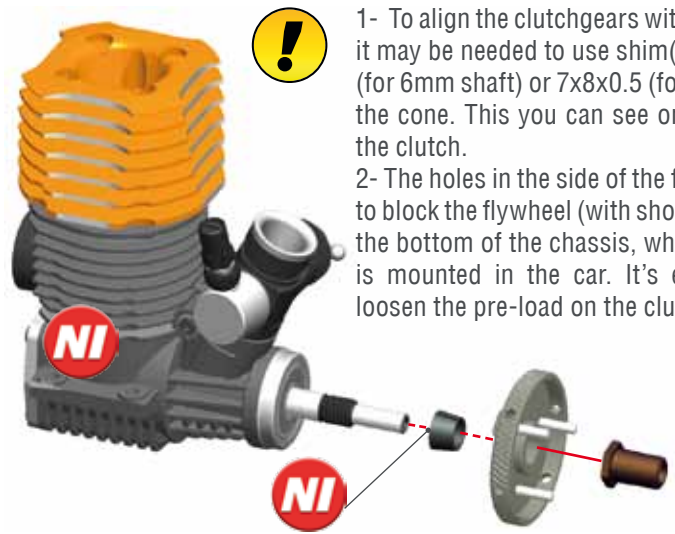

1- To align the clutchgears with the 2-speed gears, it may be needed to use shim(s) 6x8x0.5mm (for 6mm shaft) or 7x8x0.5 (for 7mm shaft) behind the cone. This you can see only after assembling the clutch.

2- The holes in the side of the flywheel can be used to block the flywheel (with short allen tool) through the bottom of the chassis, when the engine/clutch is mounted in the car. It's easier to tighten or loosen the pre-load on the clutch spring that way.



56.2



Note the orientation of the flyweights. Use the right hole for having a more aggressive clutch

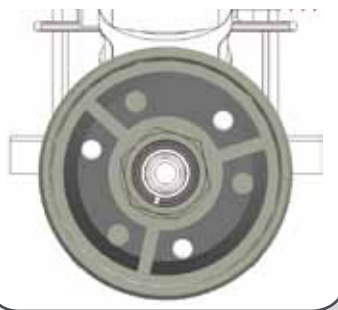

STEP 57.1

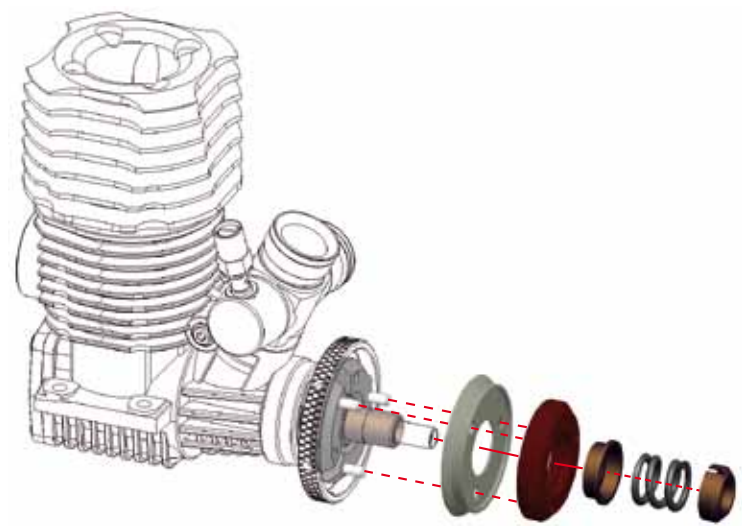

57.2

For adjusting the default clutch spring tension:

- 1- Screw in the adjusting nut all the way.
- 2- Unscrew it one and a half turns.
- 3- Fine tune the setup of your clutch on the track according to your driving style, track and weather conditions.

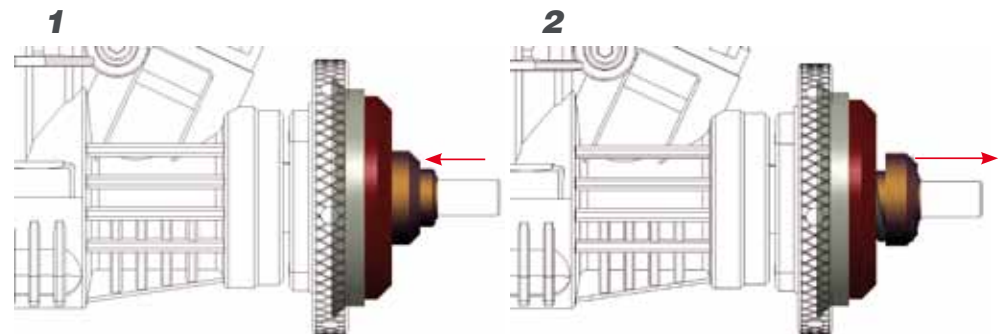

STEP 58.1

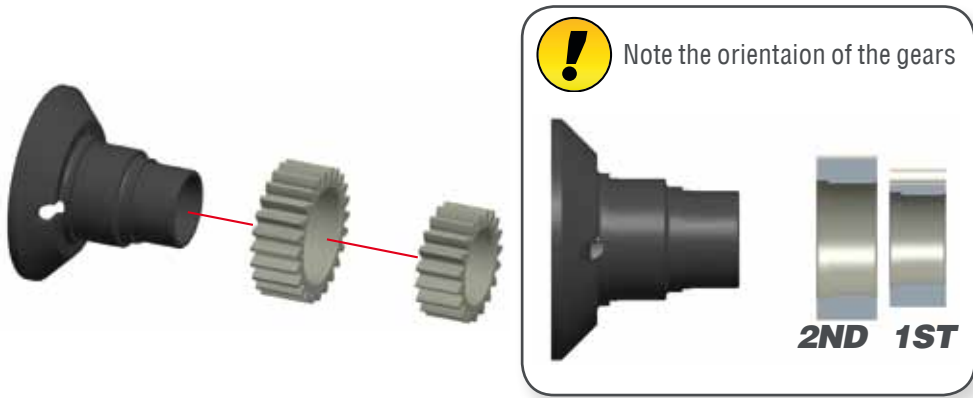

STEP 58.2

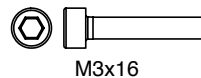
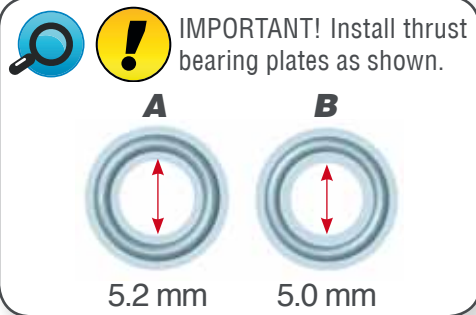
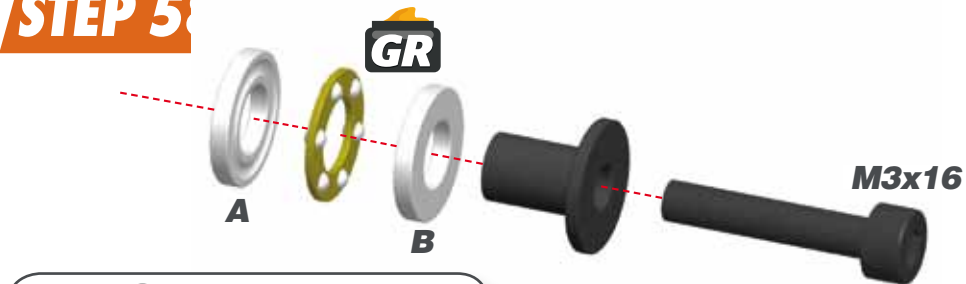

STEP 59.1

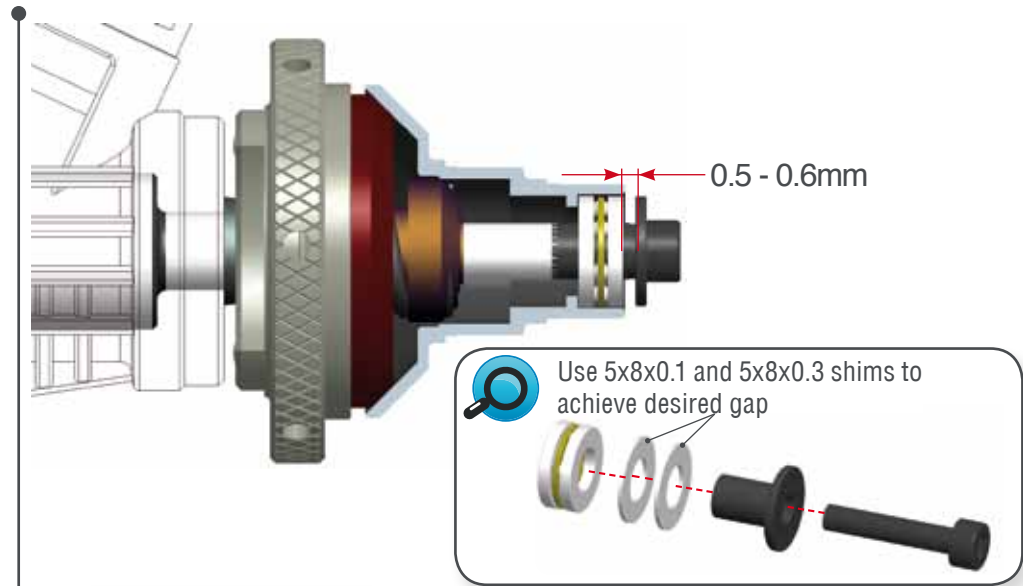

STEP 59.2

SETTING THE CLUTCH END PLAY

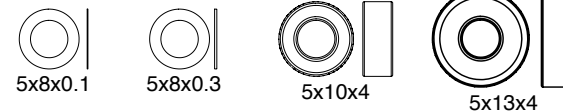
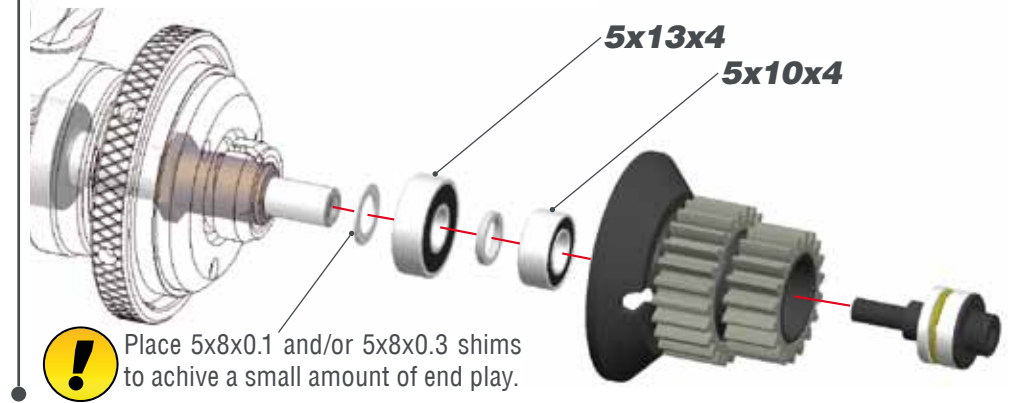

STEP 60.1 bag 13

STEP 60.2

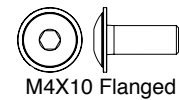
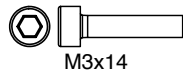
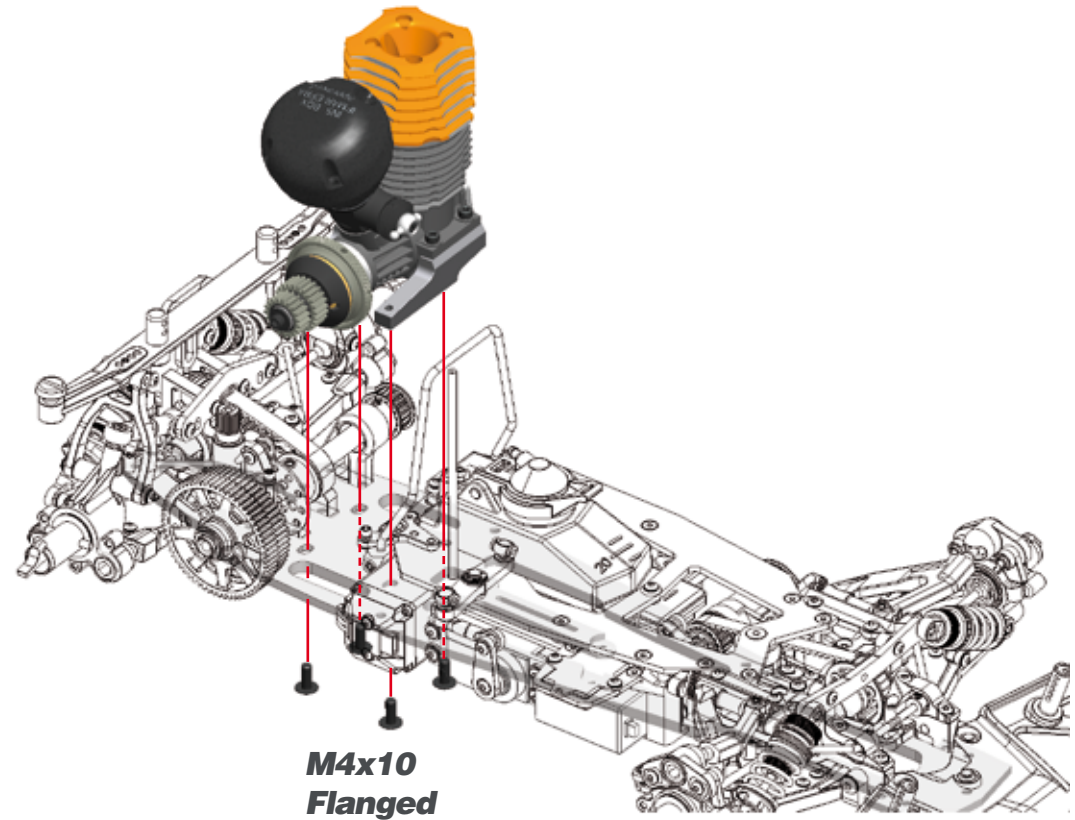

STEP 61

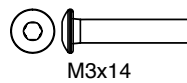
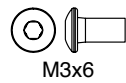
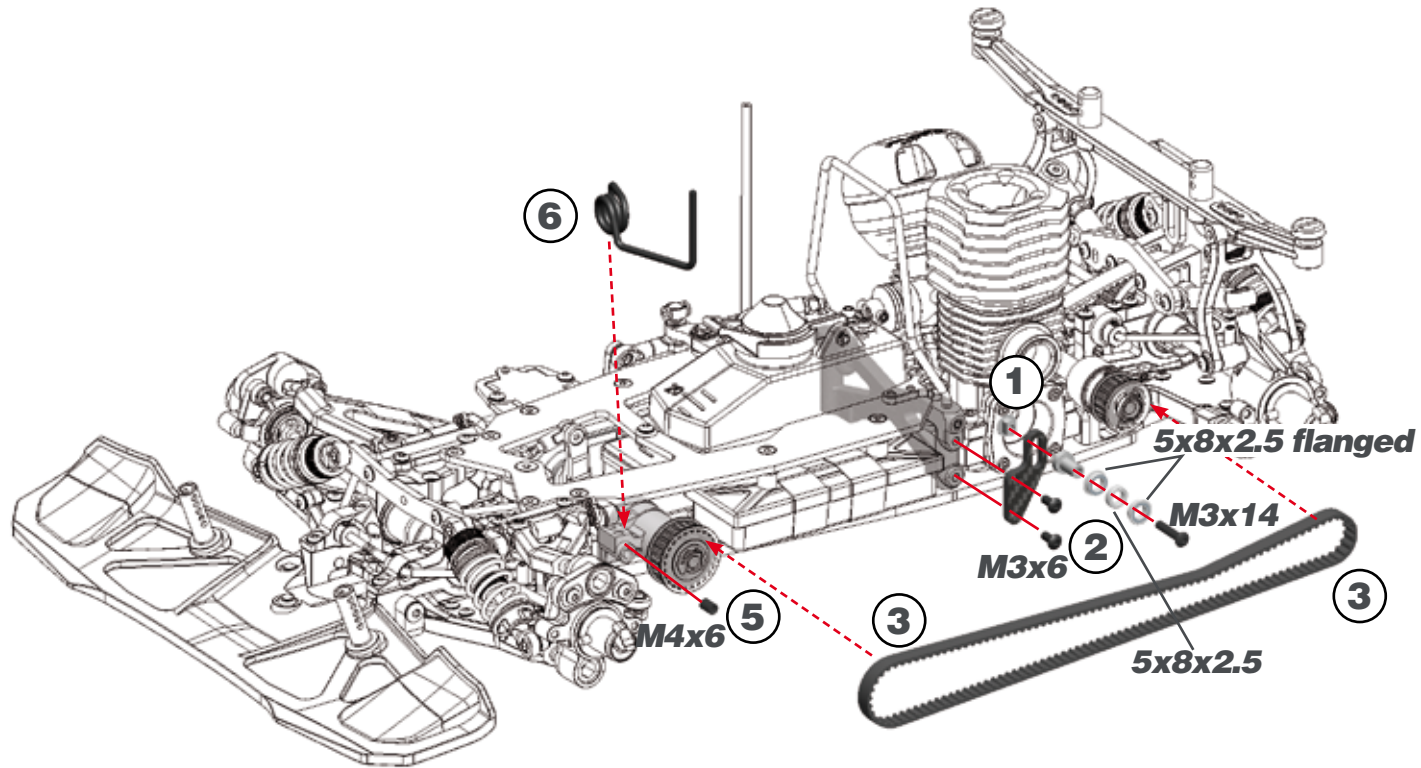

STEP 62.1

STEP 62.2

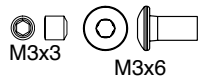
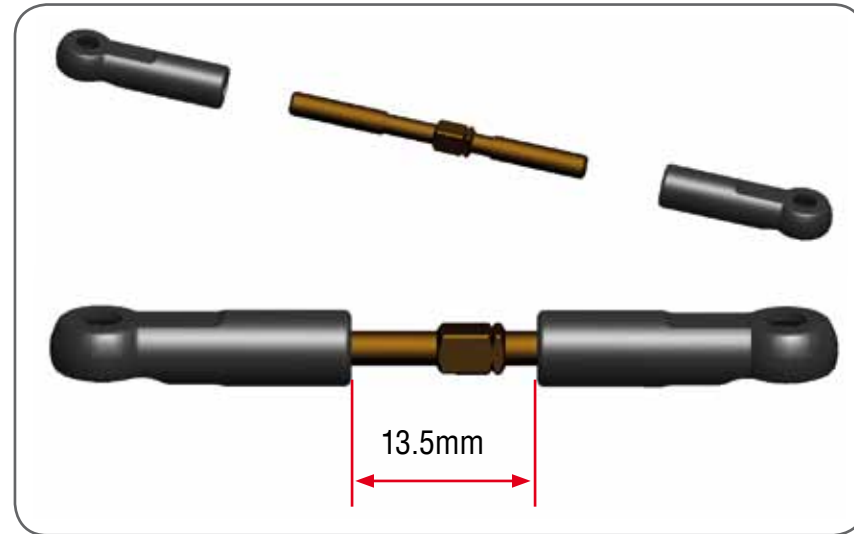
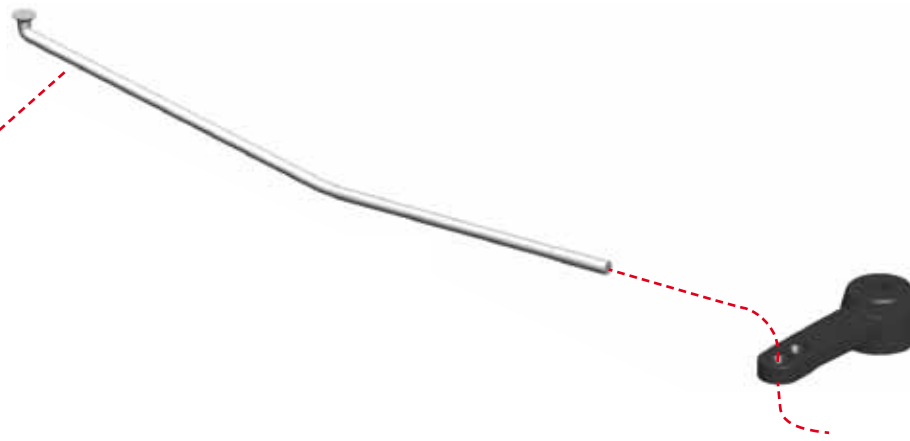
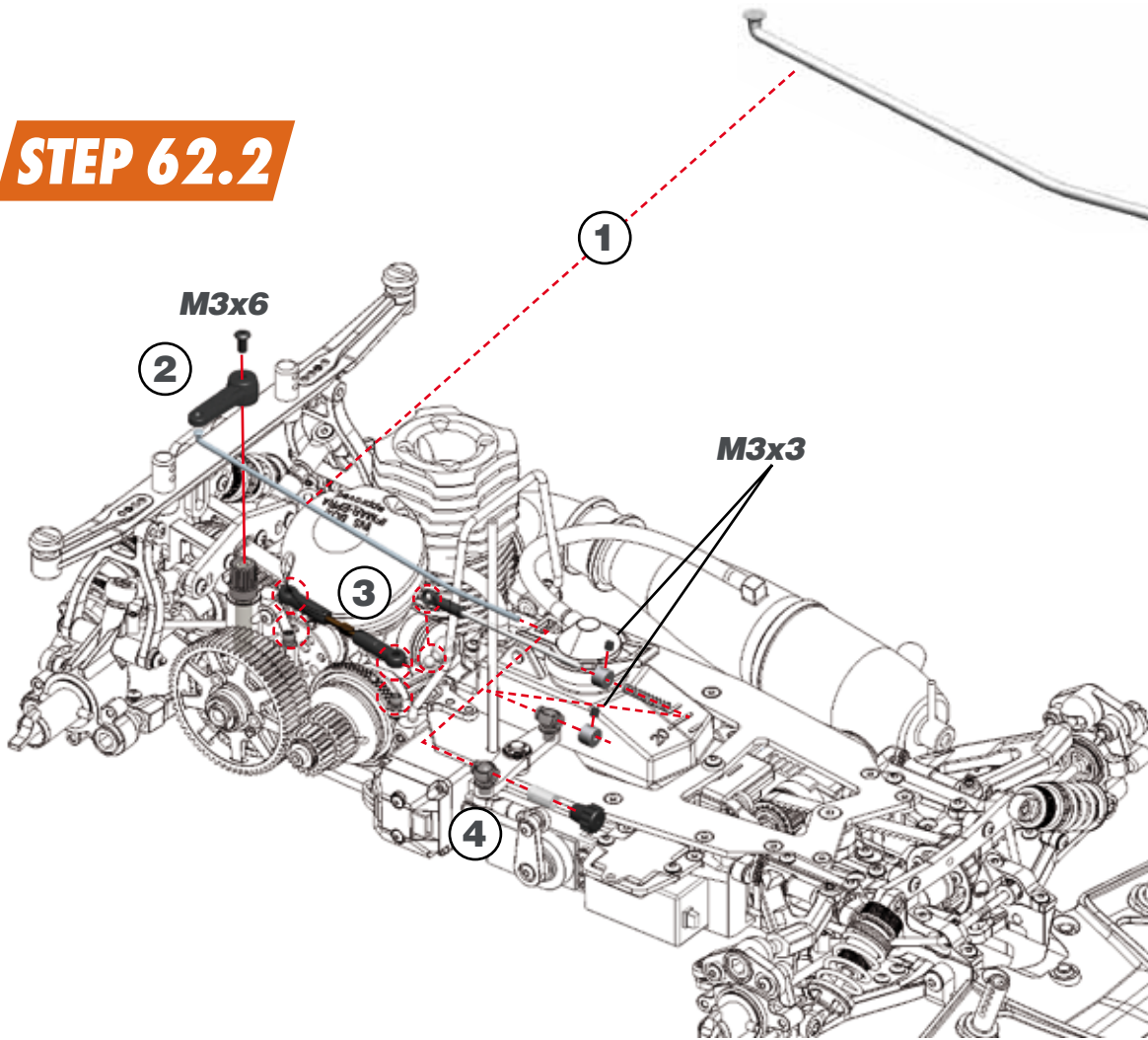

STEP 63

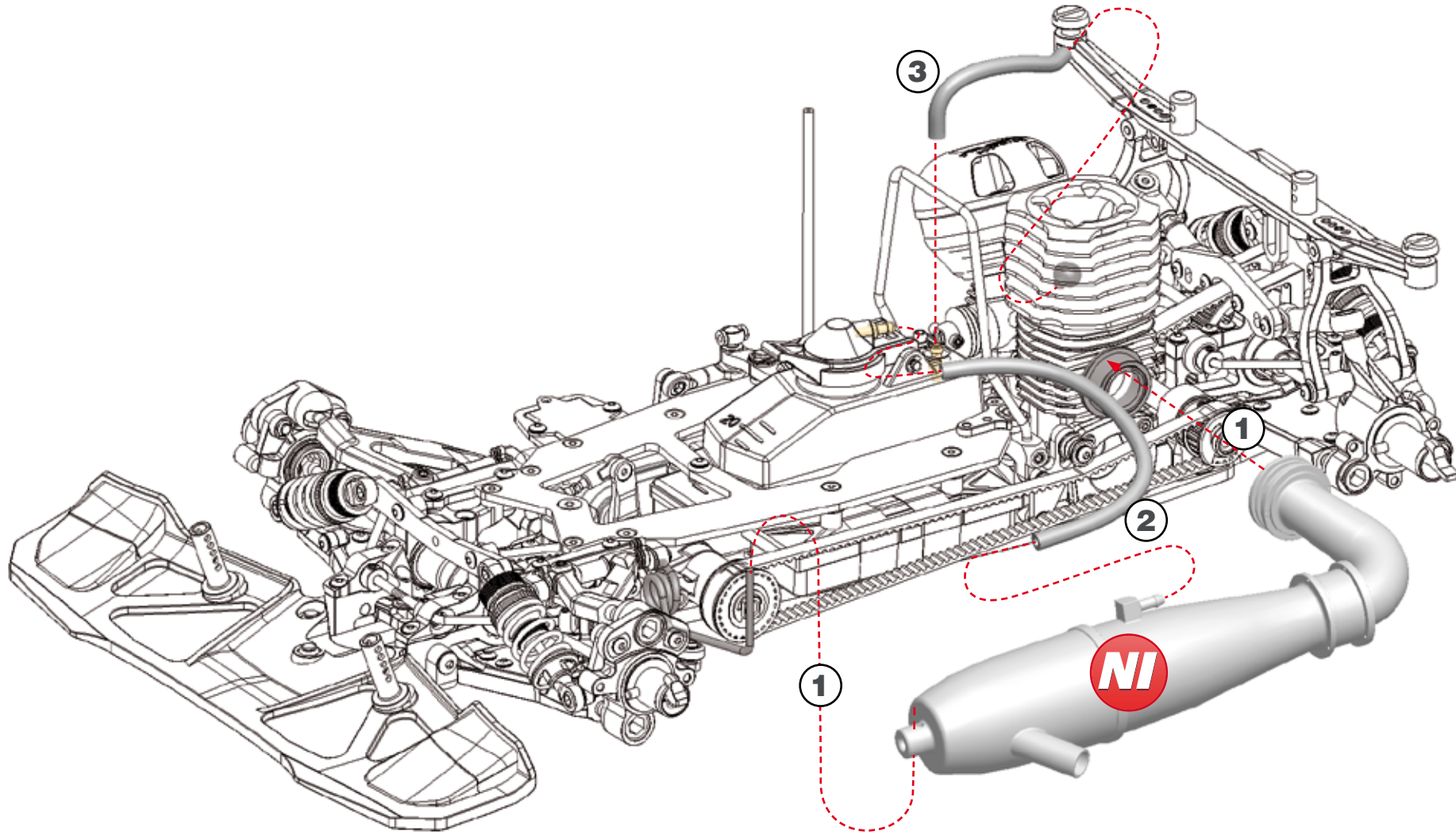

STEP 64

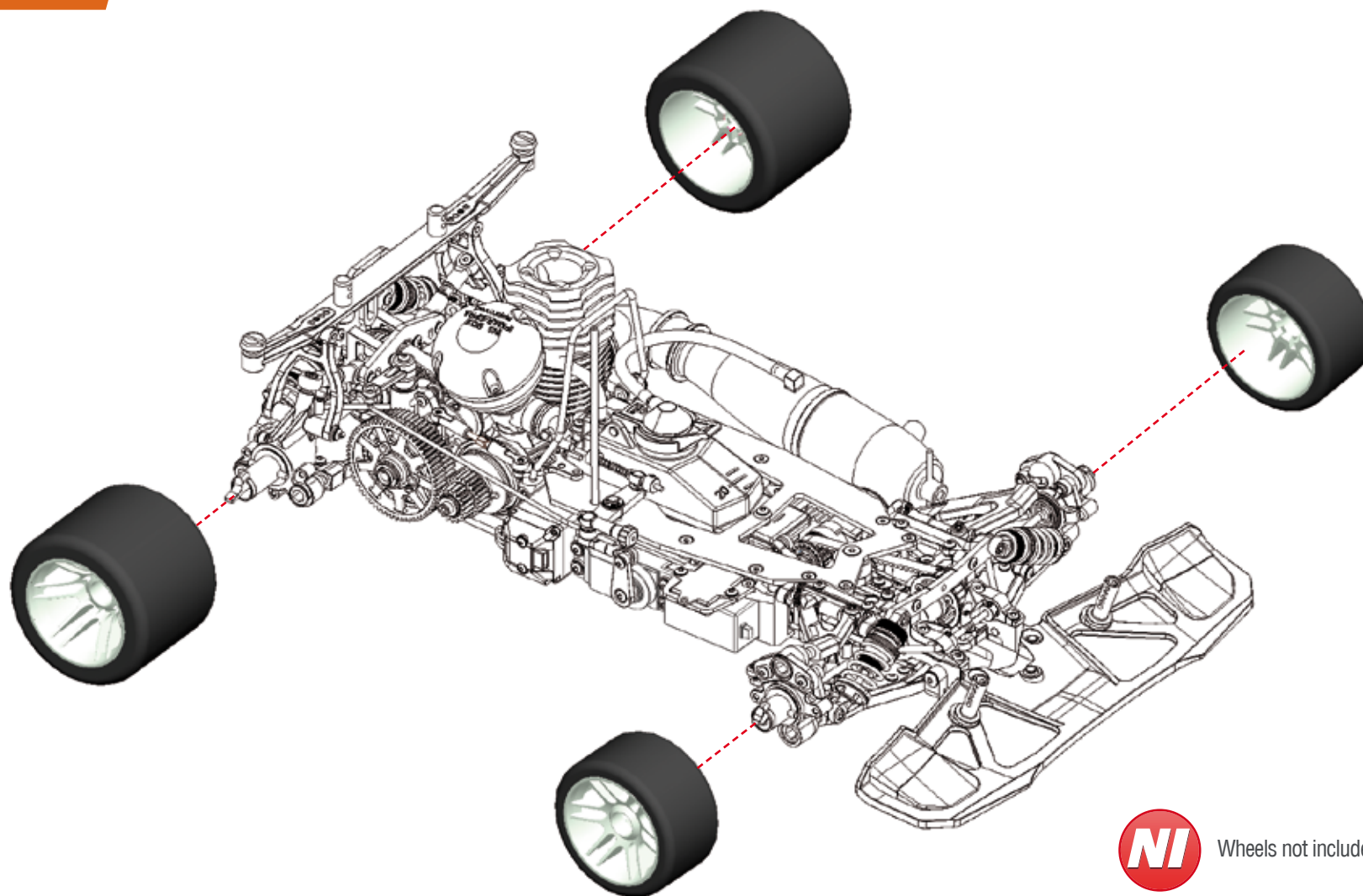

NI Wheels not included

CLUTCH and GEARBOX EXPLODED VIEW

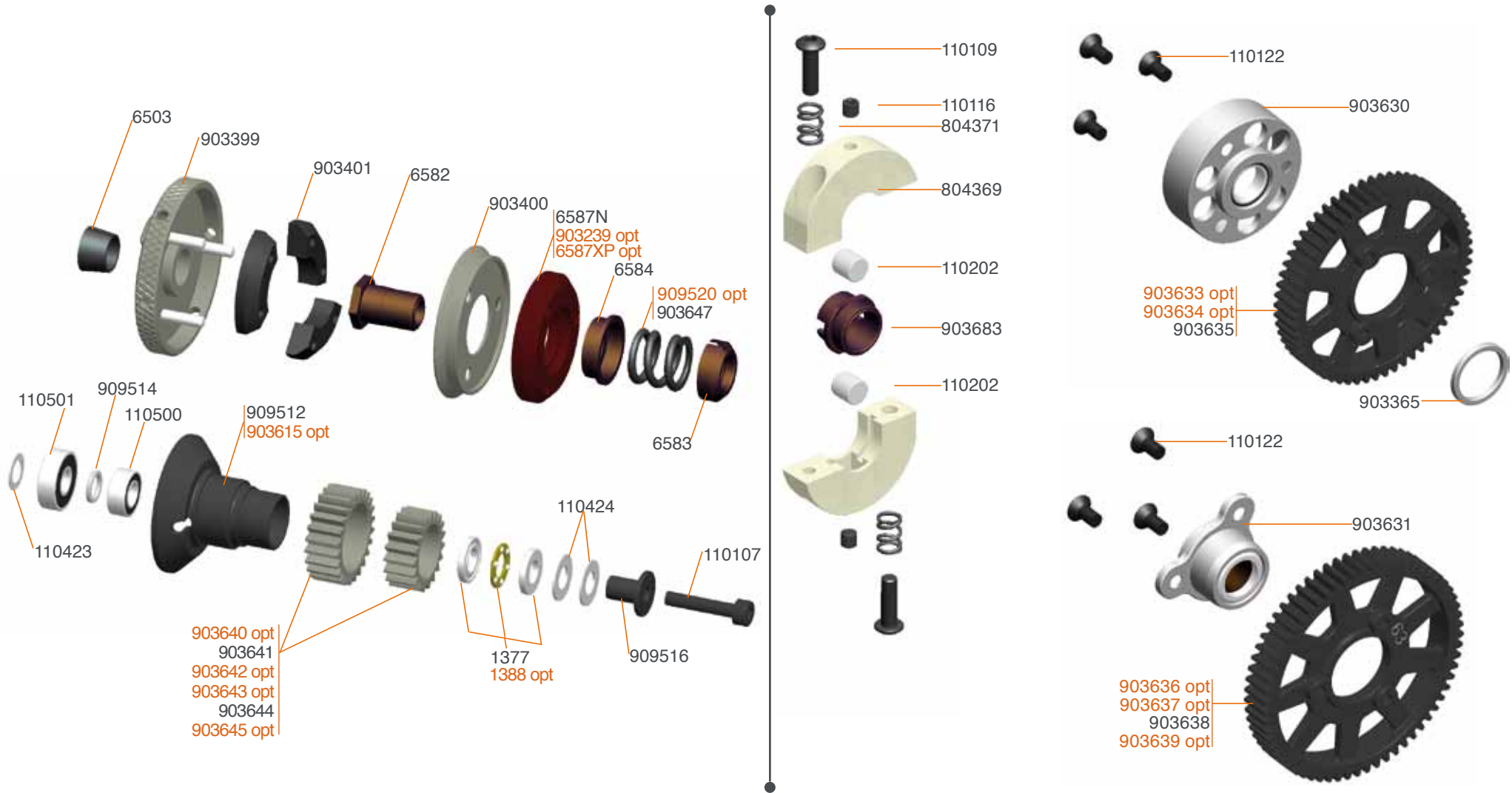

- 6587XP Centax clutch shoe black XP
- 903239 Centax-2 clutch shoe red
- 903615 Clutch housing centax 2 alu coated
- 903633 2-speed gear 56T SL8 XLI
- 903634 2-speed gear 57T SL8 XLI

- 903636 2-speed gear 61T SL8 XLI
- 903637 2-speed gear 62T SL8 XLI
- 903639 2-speed gear set SL8 (6) XLI
- 903640 Centax gear-pinion alu 18T XLI
- 903642 Centax gear-pinion alu 20T XLI

- 903643 Centax gear-pinion alu 23T XLI
- 903645 Centax gear-pinion alu 25T XLI
- 903646 Centax gear-pinion alu set XLI (6)
- 909520 Centax II coilspring 1.8 hard

OPT

SHOCKS EXPLODED VIEW

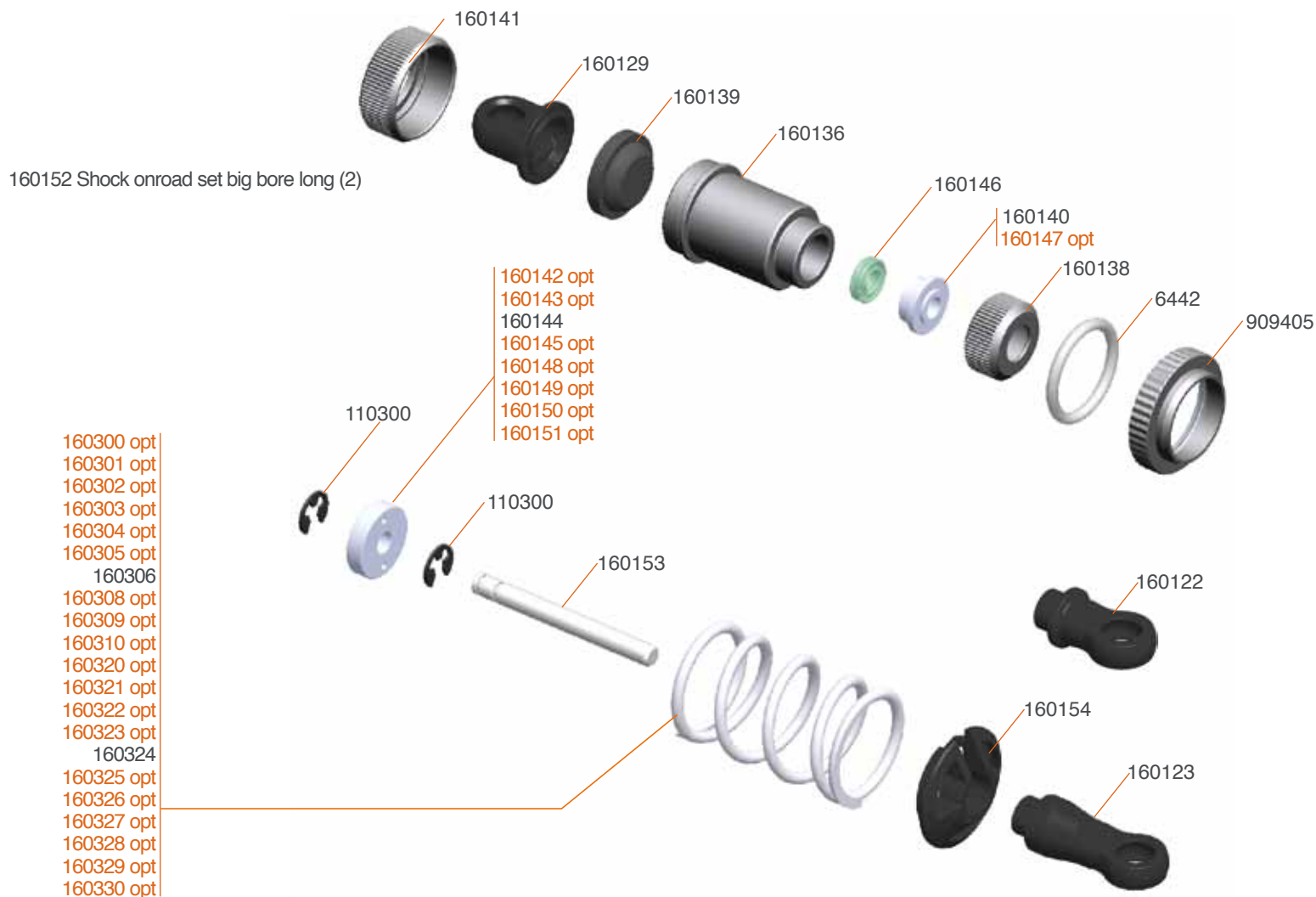

- 160142 Shock onroad big bore piston 1 hole (4)
- 160143 Shock onroad big bore piston 2 hole (4)
- 160144 Shock onroad big bore piston 3 hole (4)
- 160145 Shock onroad big bore piston 4 hole (4)
- 160146 Shock onroad big bore X-ring (4)
- 160147 Shock onroad big bore bushing LF (4)
- 160148 Shock onroad big bore piston 1 hole LF (4)
- 160149 Shock onroad big bore piston 2 hole LF (4)
- 160150 Shock onroad big bore piston 3 hole LF (4)
- 160151 Shock onroad big bore piston 4 hole LF (4)

- 160300 Spring white L23 (2.3/13) (2)
- 160301 Spring yellow L23 (2.8/16) (2)
- 160302 Spring orange L23 (3.4/19.5) (2)
- 160303 Spring red L23 (4.1/23.5) (2)
- 160304 Spring pink L23 (4.9/28) (2)
- 160305 Spring blue L23 (5.8/33) (2)
- 160307 Spring green L23 (8/45.5) (2)
- 160308 Spring grey L23 (9/51.5) (2)
- 160309 Spring black L23 (10/57) (2)
- 160310 Spring-set short (5x2)

- 160320 Spring white L27 (2.3/13) (2)
- 160321 Spring yellow L27 (2.8/16) (2)
- 160322 Spring orange L27 (3.4/19.5) (2)
- 160323 Spring red L27 (4.1/23.5) (2)
- 160325 Spring blue L27 (5.8/33) (2)
- 160326 Spring purple L27 (6.8/39) (2)
- 160327 Spring green L27 (8/45.5) (2)
- 160328 Spring grey L27 (9/51.5) (2)
- 160329 Spring black L27 (10/57) (2)
- 160330 Spring set L27 set (5x2)



REAR EXPLODED VIEW

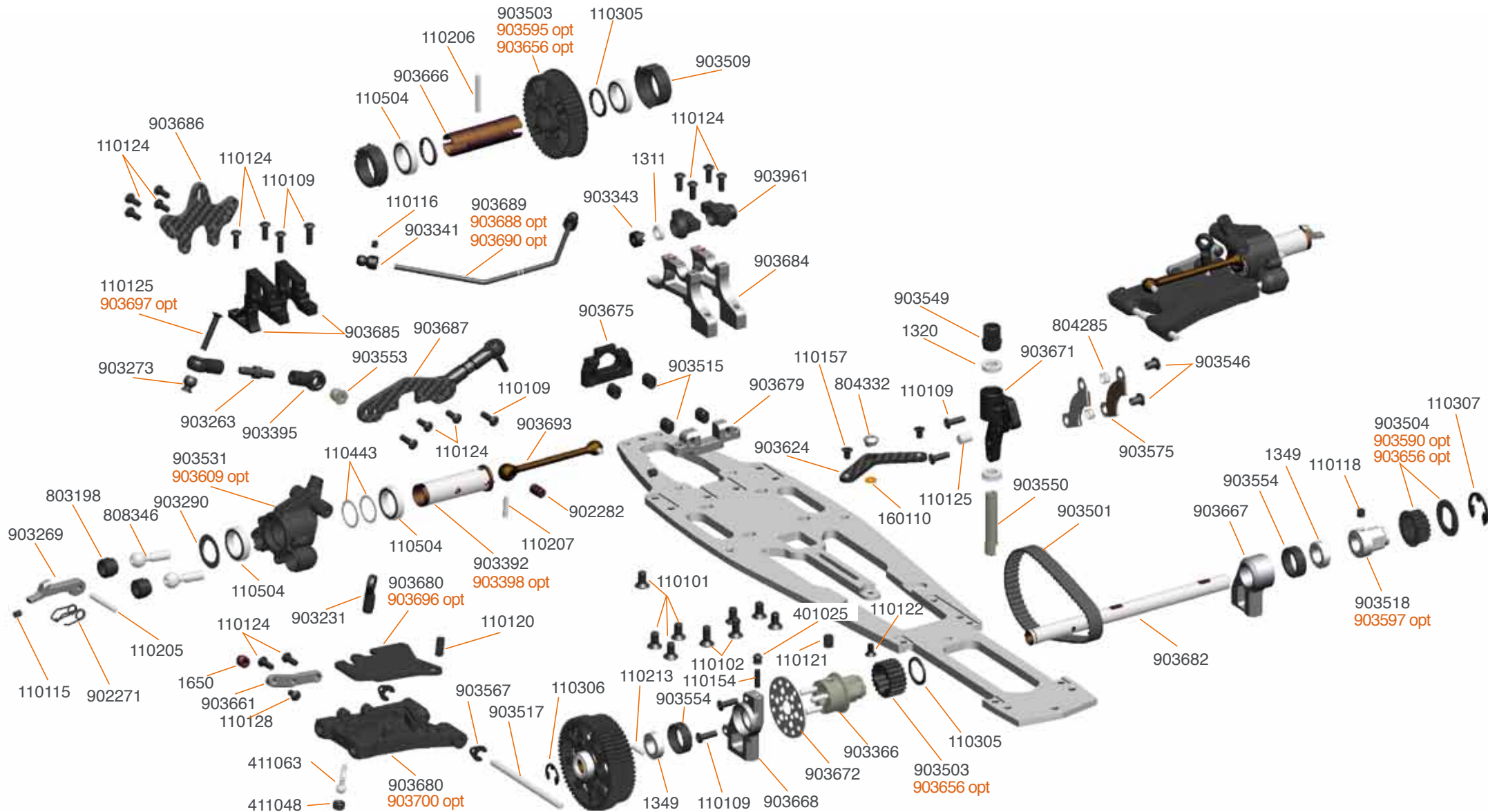

903595 Pulley rear axle 48T alu
 903398 Wheelaxle cvd RR alu (2)
 903590 Pulley 2-sp axle 19T alu
 903597 Pulley adaptor 19T light
 903609 Upright (2) hard

903656 Pulley set low friction 977 (6)
 903688 Antiroll bar FR/RR soft S988
 903690 Antiroll bar FR/RR hard S988
 903696 Wishbone insert carbon RR lw (2)S988
 903697 Camberlink riser 1/8 (2)

903700 Wishbone RR lw L+R hard S988

FRONT 1 EXPLODED VIEW

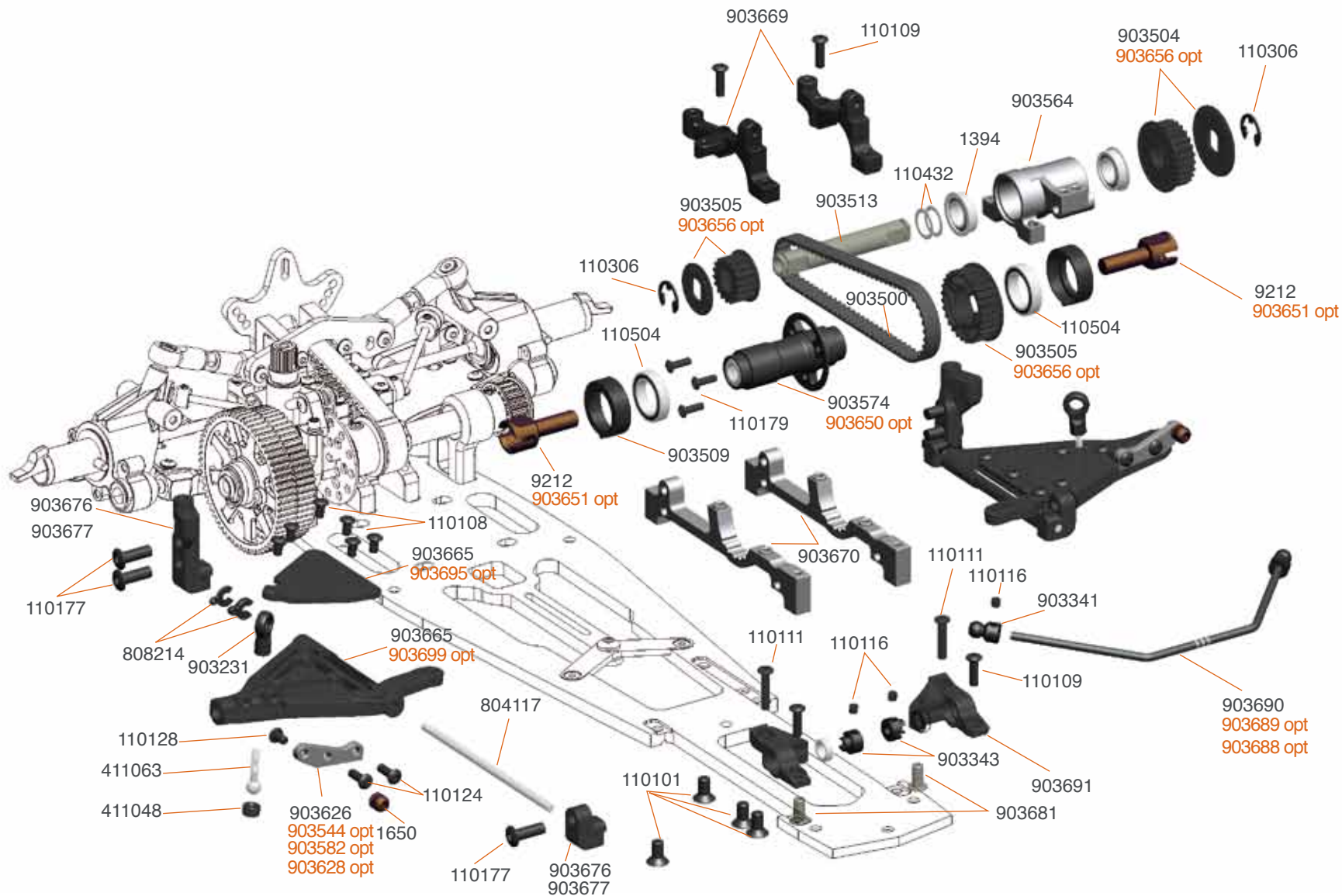

- 903544 Shock extension bracket FR alu (2)
- 903582 Shock extension bracket FR carbon (2)
- 903628 Shock extension bracket FR wide carbon (2)
- 903650 Oneway front axle Hard anodized
- 903651 Inner driveshaft adapter light

- 903656 Pulley set low friction 977 (6)
- 903688 Antiroll bar FR/RR soft S988
- 903689 Antiroll bar FR/RR medium S988

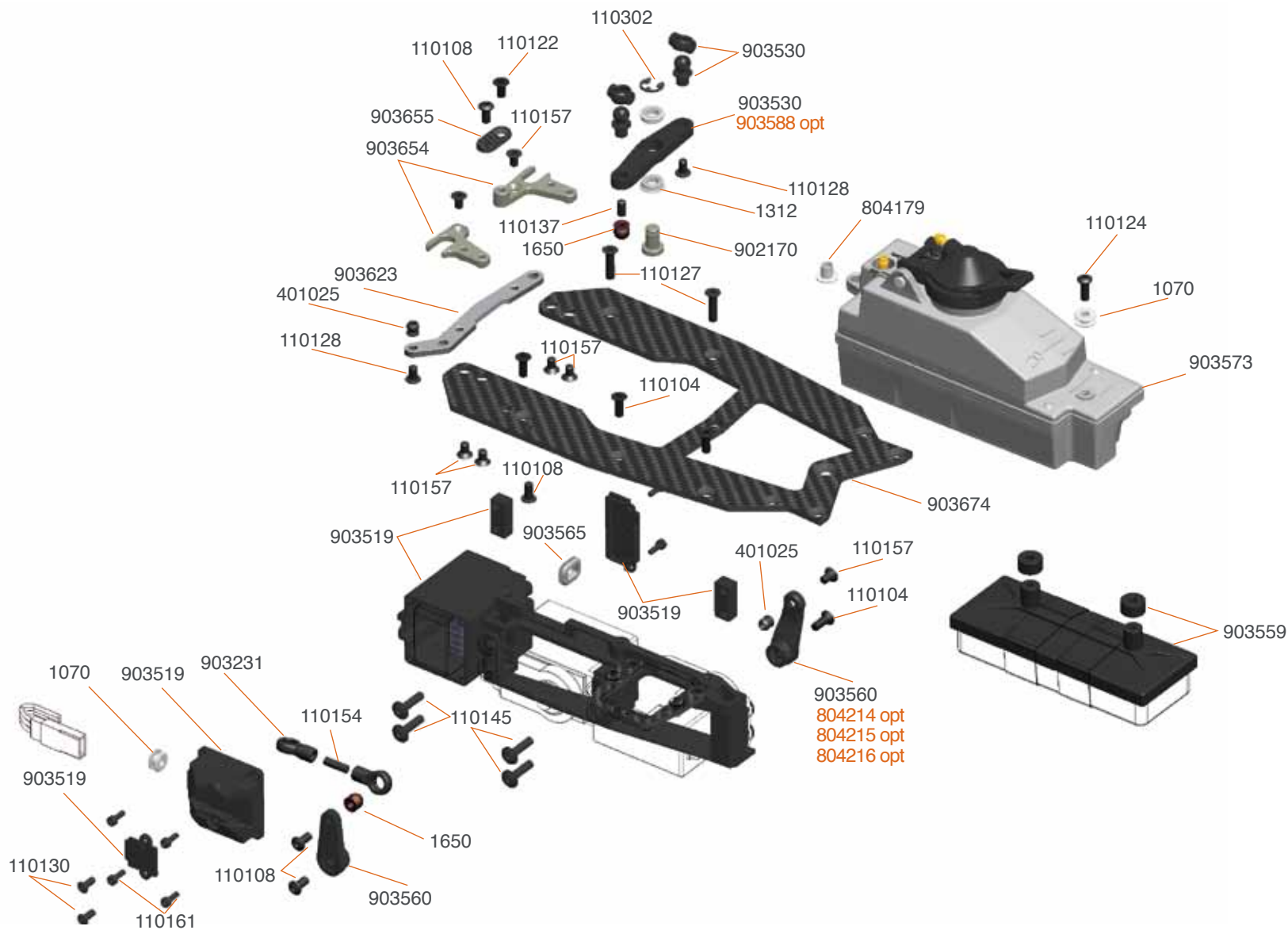

- 804214 Steering lever 23T alu
- 804215 Steering lever 24T alu
- 804216 Steering lever 25T alu
- 903588 Throttle lever alu

SHOCKS EXPLODED VIEW

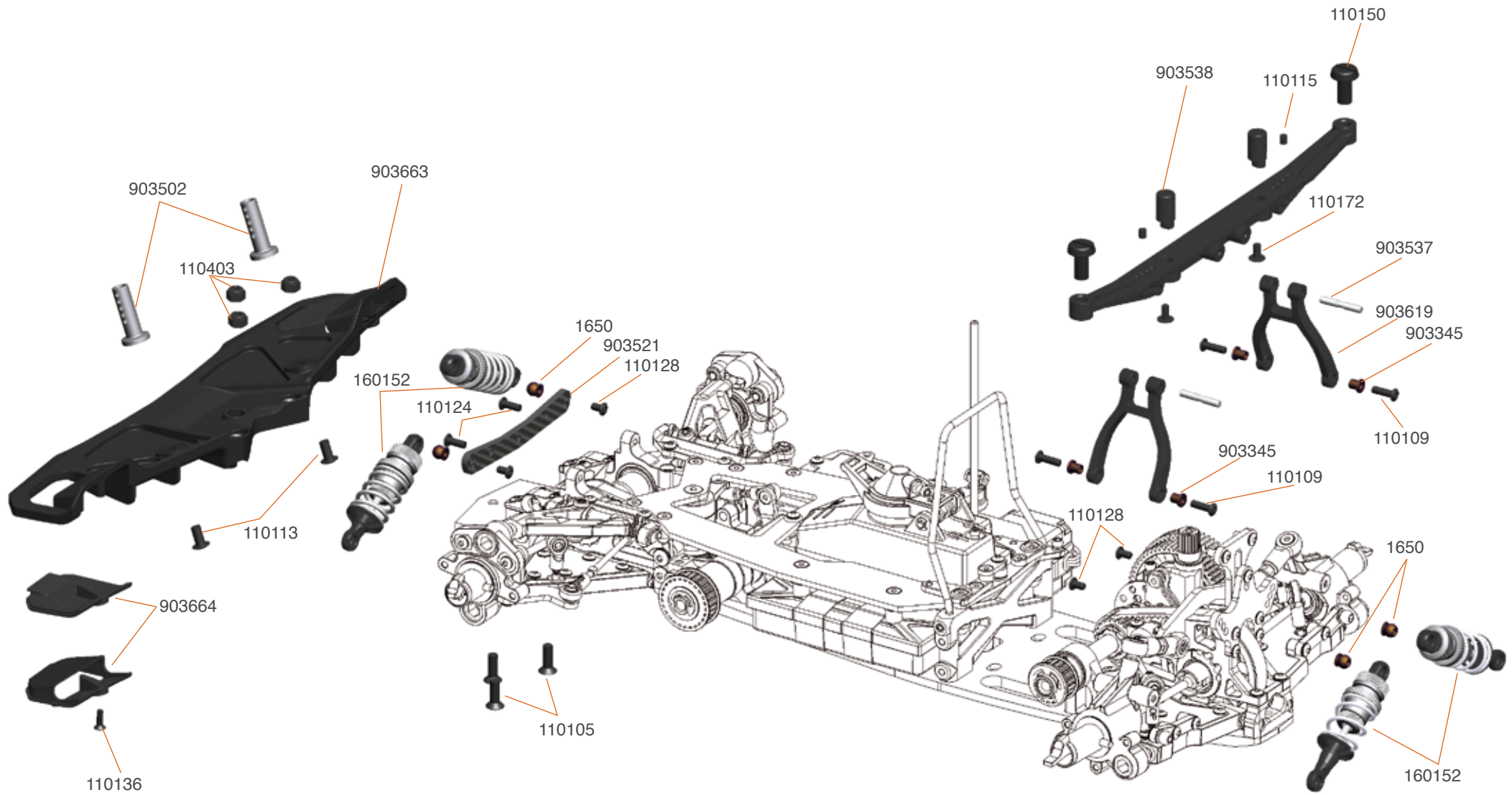

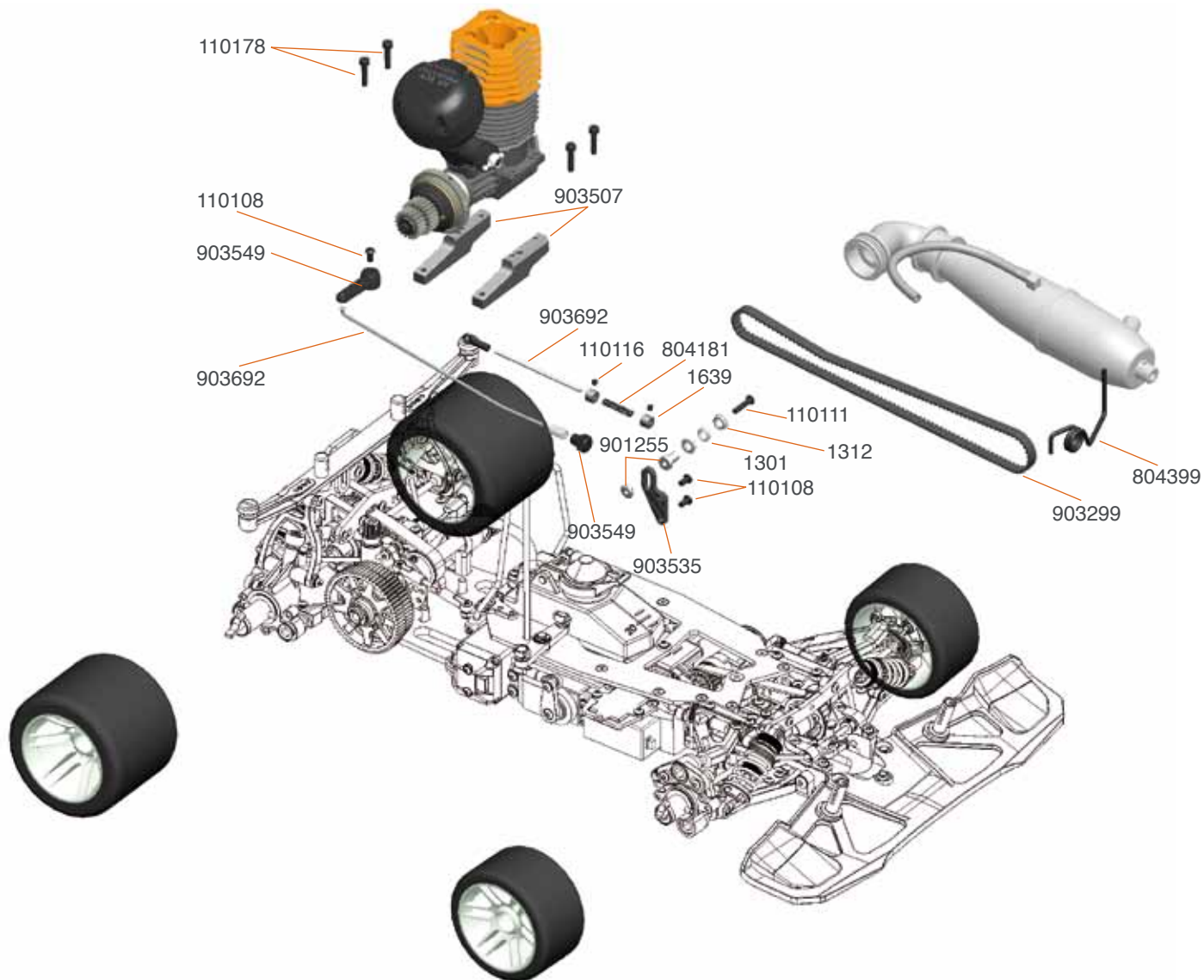

9888
VIPER

GP 1/8 scale onroad

SPT
SERPENT
INNOVATIONS